

HITACHI

EH 4500

Maximum Payload
255,4 Tonne (281.6 Ton)

**Maximum Payload
with Standard Liners**
241,8 Tonne (266.6 Ton)

Maximum GMW
435 456 kg (960,000 lb)

Engine
Cummins QSK60-L
Detroit Diesel 16V-4000
Rated Output 2 013 kW (2,700 hp)



Specifications: EH4500



ENGINE

Make	Detroit Diesel w/DDEC IV	Cummins
Model	16V-4000	QSK60-L
Type	4 Cycle	4 Cycle
Aspiration	Turbocharged & low temperature aftercooled	Two stage (twin) turbocharged & low temperature aftercooled & intercooled
Gross Power @ 1900 rpm (SAE J1995)	2 013 kW 2,700 hp	2 013 kW 2,700 hp
Net Power @ 1900 rpm (SAE J1349)	1 973 kW 2,646 hp	1 963 kW 2,633 hp
Maximum Torque @ 1350 rpm (SAE 1995)	10 933 N-m 8,064 lb-ft	10 629 N-m 7,840 lb-ft
No. Cylinders	16	16
Bore & Stroke	mm 165 x 190 in 6.5 x 7.48	mm 159 x 190 in 6.26 x 7.48
Displacement	liters in³ 65,0 3,966	liters in³ 60,2 3,672
Starting	Electric	Electric



ELECTRIC DRIVE

Controls and Alternator

Euclid AC drive technology uses Siemens controls and proven GTO inverter phase modules. Dynamic retarding capacity to zero speed using solid state technology. Alternator direct mounted to engine.

Wheel Motors

Euclid AC drive technology, developed in conjunction with Siemens, provides superior performance with higher top speeds, better gradeability and stronger retardation. Brushless operation reduces maintenance and running costs. Long life to overhaul means less downtime and reduced running costs.

	Standard	Optional
Planetary Ratio	35.816:1	40.789:1
Maximum Speed	km/h 62,0 mph 39.0	km/h 54,4 mph 34.0



TIRES

Standard - Front and Rear	Rim Width
50/80 R57(**)E4 Radials	mm in 864 34
Optional - Front and Rear	
50/90 R57	mm in 864 34

Certain job conditions may require higher TKPH (TMPH) in order to maintain maximum production. Euclid recommends evaluating the job conditions and consult the tire manufacturer to make proper tire selection. Optional rims available.



ELECTRICAL SYSTEM

Twenty-four volt system. 250 amp battery charger. Eight 12-volt, heavy-duty batteries connected in series/parallel.



BODY CAPACITY

	m ³	yd ³
Struck (SAE)	105,4	137.9
Heap 3:1	134,3	175.6
Heap 2:1 (SAE)	147,6	193.1



WEIGHTS

	Detroit Diesel		Cummins	
	kg	lb	kg	lb
Chassis with Hoist	148 017	326,322	149 512	329,617
Body	31 996	70,540	31 996	70,540
Net Machine Weight	180 014	396,862	181 508	400,157
Empty Axle Weights				
Front Axle	90 391	199,278	90 611	199,764
Rear Axle	89 623	197,584	90 897	200,393

Maximum GMW

	kg	lb
[50/80 R57(**)E4] Including Options, 50% Fuel, Operator & Payload Not to Exceed	435 456	960,000
Load Weight Distribution		
Front - 34% Rear - 66%		

Maximum Payload	255 442	563,138	253 948	559,843
-----------------	---------	----------------	---------	----------------

Note: Maximum GMW subject to EUCLID-HITACHI approval for a given application.

Options: Approximate change in Net Machine Weight:

	kg	lb		
Body Liners, Complete	13 608	30,000		
Max. Payload with Body Liners Complete	241 834	533,138	240 340	529,843
Floor	mm	in 19 3/4		
Sides and front	mm	in 10 3/8		
Corners	mm	in 19 3/4		
Canopy	mm	in 6 1/4		
Top Rails	mm	in 10 3/8		



STEERING SYSTEM

Flow-amplified, closed-center hydrostatic power steering system using two double-acting cylinders with pressure unloading type compensated piston pump and a brake actuation/steering system reservoir. Accumulators provide supplementary steering in accordance with J/ISO 5010 and constant steering rate under all conditions. A tilt/telescopic steering wheel with 35° of tilt and 57,15 mm 2.25" telescopic travel is standard.

Steering Angle			42°
Turning Diameter (SAE)	m	ft in 28,47 93.4	
Steering Pump Output (@ 1900 rpm)	l/m	gpm 249,0 65.8	
System Pressure	kPa	psi 20 685 3,000	
Filtration - Pressure line Beta G rating = 200			
Beta 10 ratio = 800			



HYDRAULIC SYSTEM

Two (2) Euclid three-stage, double-acting cylinders with cushioning in retraction, containing dual rod seals and urethane energized scrapers, inverted and outboard mounted. Separate reservoir and tandem gear pump connects with a four position electronic pilot controlled hoist valve. Electric controller is mounted to operator's seat.

Body Raise Time	s	22.2	
Hoist Pump Output @ 1900 rpm	l/min	gpm 969,0 256.0	
System Relief Pressure	kPa	psi 18 961 2,750	
Filtration - Pressure line Beta G rating = 200			
Beta 10 ratio = 800			



BRAKE SYSTEM

Brake systems meet or surpass SAE J/ISO 3450.

Service

All-hydraulic actuated braking system provides precise braking control and quick system response. The system is pressure proportioned, front to rear, for improved slippery road control.

The Euclid wet disc brake is engineered for long service life, even in the most extreme environments. The wet disc brakes are located on the rear axle and provide service braking and secondary braking functions. The brakes are of a multi-plate design and continuously oil-cooled.

Front Axle - Dry Disc

Disc Diameter Each (2 discs/axle)	cm	in 122,0 48
Brake Surface Area Per Axle	cm ²	in² 17 032 2,640
Lining Area Per Axle	cm ²	in² 6 194 960
Brake Pressure (Max.)	kPa	psi 20 685 3,000

Rear Axle - Oil-Cooled Wet Disc

Brake Surface Area Per Axle	cm ²	in² 149 993 23,248
Brake Pressure (Max.)	kPa	psi 15 170 2,200

Secondary

Dual independent hydraulic circuits within the service brake system provide fully modulated reserve braking capability. Both front dry disc and rear wet disc are automatically applied when loss of pressure is detected.

Parking

Four spring on, hydraulic off armature disc brake heads provide parking capabilities. The braking system complies with J/ISO 3450.

Retarder

Superior retardation to zero speed on grades is achieved through AC wheel motors in conjunction with the Siemens resistor grid package. A recessed grid box, located on the service deck, enhances operator visibility. Cooling for the grid package is achieved with forced air flow provided by a blower driven by a single electric motor.

Maximum dynamic retarding with continuous rated blown grids:			
Standard	kW	hp 3 505 4,700	
Optional	kW	hp 4 474 6,000	



COMMAND CAB III

Integral ROPS/FOPS

Command Cab III integral ROPS (Rollover Protective Structure) is standard in accordance with J/ISO 3471.



Double wall construction of 11 gauge inner and outer steel panels produces a more structurally sound cab. Foam rubber lining material along with foam rubber-backed carpeting and multiple layered floor mat act to absorb sound and control interior temperature. A properly maintained cab from Euclid, tested with doors and windows closed per work cycle procedures in SAE J1166, results in an operator sound exposure L_{eq} (Equivalent Sound Level) of 81 dB(A). A three-point rubber iso-mount arrangement to the deck surface minimizes vibration to the operator compartment.

Monitoring System

CONTRONIC II monitors and diagnoses all onboard systems including Siemens drive system and engine. Data links offer complete integration, while a single multi-language Liquid Crystal Display (LCD) clearly details machine functions. Downtime is minimized with faster and more reliable troubleshooting and analysis.

HAULTRONIC II load weighing system offers benefits such as better equipment utilization on the jobsite, accurate unit and fleet production results, and benchmark unit statistics against fleet results. Cycle time, distance and cycle count can all be measured and recorded to further improve job productivity. Haultronic II is fully integrated with CONTRONIC II vehicle monitoring system and display interface, avoiding potential failure or error common in aftermarket systems.

Excellent Serviceability

A removable front closure allows easy access to the service brake valve and heater connections. The upper dash utilizes four (4) removable panels that house gauges and customer options, each individually accessible. A removable closure located behind the seat provides easy access to the shifting control, CONTRONIC II, and all electrical junction points.

Comfort and Ease of Operation

A wrap-around style dashboard positions controls within easy reach and visual contact. A full complement of easy-to-read gauges, CONTRONIC II monitoring and warning system, a spacious environment, six-way adjustable air seat, tilt/telescopic steering wheel, filtered ventilation, door locks, and a full size trainer seat, all contribute to operator safety and comfort.

Equipment & Dimensions: EH4500



SUSPENSION

Front and Rear Suspension

For years, Euclid haulers have enjoyed an industry-wide reputation for superior suspension systems. That experience and knowledge has now been pushed to the next level, to develop the truly advanced ACCU-TRAC suspension for the EH4500.

The new ACCU-TRAC suspension system features independent trailing arms for each front wheel with NEOCON struts, containing energy absorbing gas and compressible NEOCON-E™ fluid, mounted between the king pins and the frame. This arrangement allows a wider front track that provides a better ride, improved stability and a reduced turning circle. The rear NEOCON struts are mounted in a more vertical position which allows a more pure axial loading and reduces the tractive and breaking forces transmitted to the nose cone.

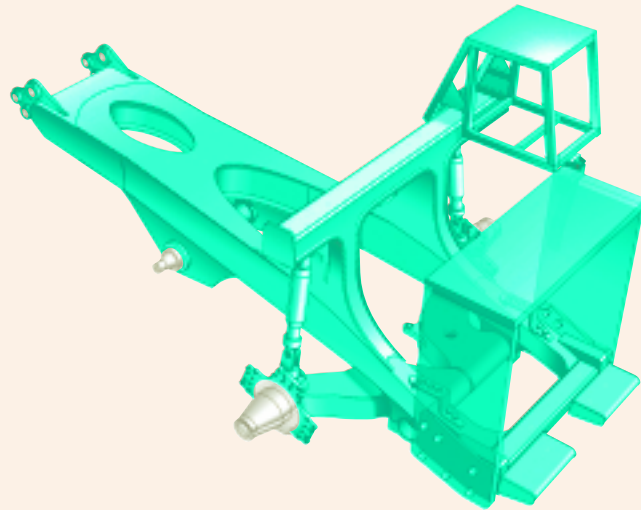

NEOCON struts outperform competitive strut designs by improving isolation, stability, and control. Improved isolation means reduced impact loading on the structural members of the machine and greater operator comfort, resulting in longer equipment life and productivity. Improved stability means more consistent dynamic response of the machine to fluctuating load energy, resulting in predictable machine performance. Improved control also means better machine maneuverability.

The Euclid frame and ACCU-TRAC suspension system are designed to work in unison to provide maximum structural integrity and operator comfort. The fabricated rectangular frame rail construction provides superior resistance to bending and torsional loads while eliminating unnecessary weight. The unique ACCU-TRAC independent trailing arm suspension absorbs haul road input, minimizing suspension-induced frame twisting while providing independent tire action. NEOCON ride struts are mounted with spherical bushings, eliminating extreme sidewall forces by ensuring a purely axial input to the ride strut. The wide track stance of the ACCU-TRAC suspension system and the long wheel base assure a more stable, comfortable ride.



FRAME

Full fabricated box section main rails with section height tapered from rear to front. Wider at the rear to support the loads and narrower at the front to allow for engine accessibility. One piece top and bottom flanges that eliminate cross member tie in joints and provide a large exposed center area for access to major components. Large radii minimize stress concentrations. Welded joints are oriented longitudinally to the principal flow of stress for greater durability and more strength. Frame utilizes 345 N/mm² **50,000 psi** yield strength alloy steel that is robotically welded to ensure high quality welds.



BODY

Flat chute type, sloped floor, continuously exhaust-heated. Extended canopy protects service deck area. High tensile strength 400 BHN abrasion resistant alloy steel is used in thicknesses of:

	mm	in
Floor	19	3/4
Front	10	3/8
Sides	10	3/8
Canopy	6	1/4
Corners	16	5/8

High strength 690 N/mm² **100,000 psi** alloy steel is also used for the canopy side members and floor stiffeners. The body is rubber cushioned on the frame.

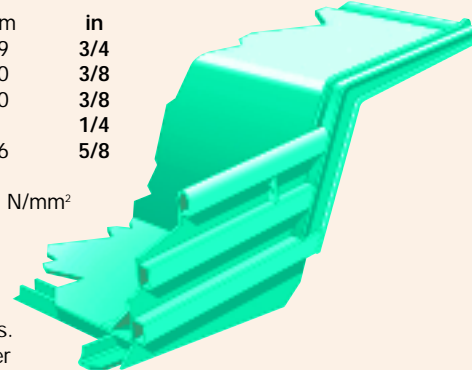

The Euclid horizontal stiffener design minimizes stress concentrations, by dissipating load shocks over the entire body length. Closely spaced stiffeners provide additional protection by minimizing distances between unsupported areas.



SERVICE CAPACITIES

	liters	gallons
Accumulator	76,0	20.0
Crankcase (incl. filters)		
Detroit Diesel S-4000	220,7	58.3
Cummins QSK60-L	265,0	70.0
Cooling System		
Detroit Diesel S-4000	522,3	138.0
Cummins QSK60-L	522,3	138.0
Fuel Tank	3 785	1,000
Hydraulics		
Hoist System	780,0	206.0
Steering System	231,0	61.0
Euclid Planetary Drives	257,4	68.0
Front Wheels	27,0	7.0
Windshield washer	7,6	2.0

STANDARD EQUIPMENT

GENERAL

Access ladders
Air conditioning
Air cleaner protection
All-hydraulic braking
Automatic lubrication system
Battery box, on deck
Battery isolation switch
Body down indicator, mechanical
Body prop pins
Centralized service panel
Continuous heated body
Cruise control, propel/retard
Electric horn, dual
Electronic hoist control
Electric start
Engine access ladders (2)
Engine self load test
Extended body canopy
Fan guard
Fast fueling system, on tank
Fuel gauge on tank
Ground level engine shutdown switch

CAB

Acoustical lining
Air filtration/replaceable element
Air suspension seat, 6 position
Ash tray
Auxiliary outlet, 12 volt
Cab interior light
Cigar lighter
Door locks
Engine starter/shutdown switch
Full trainer seat
Heater and defroster 26,000 Btu
Integral ROPS/FOPS cab
ISO driver envelope

GAUGES AND INDICATORS

CONTRONIC II monitoring and alarm system, multi-function indicator lights:

Air filter restriction
Alternator
Body up indicator
Blower loss
Brake supply pressure
Central warning
Engine oil pressure
Engine coolant temperature
High beam indicator
Hoist filter restriction
Hoist oil temperature
Hoist supply pressure
Parking brake applied
Payload monitoring
Steering filter restriction
Steering oil temperature
Traction system fault
Turn signals/hazard
Wheel motor temperature

MACHINE LIGHTS

Back-up lights, (2)
Clearance lights, LED (4)
Dual combination stop and tail lights, LED (2)
Dynamic retarding light, LED (1)
Engine compartment lights, (2)

Guard rails around platform
HAULTRONIC II load weighing system
HID headlights
Hoist kickout
Ladder lights
Mirrors, right and left
Mud flaps
NEOCON suspension struts
Operator arm guard
Propulsion interlock, body up
Radiator grille guard
Retarder grid package, 14 element
Reverse alarm
Rock ejector bars
Supplementary steering system, accumulator
Thermatic fan
Tires, 50/80 R57(**)E4
Tow hooks, front and rear
Two-speed overspeed setting
Wiggins fast fueling

Load and hold switch
Modular instrumentation
Operator seat belt
Roll down windows
Rubber floor mat
Safety glass
Sun visor
Tilt/telescopic steering
Tinted glass all windows
Trainer seat belt
Windshield washer
Windshield wiper

Gauges:

Brake temperature
Engine coolant temperature
Fuel gauge in cab (LCD)
HAULTRONIC II
Hourmeter (LCD)
Speedometer
Steer/brake supply pressure
Steer accumulator pre-charge (LCD) gauge
Tachometer
Voltmeter (LCD)
Wheel motor temperature

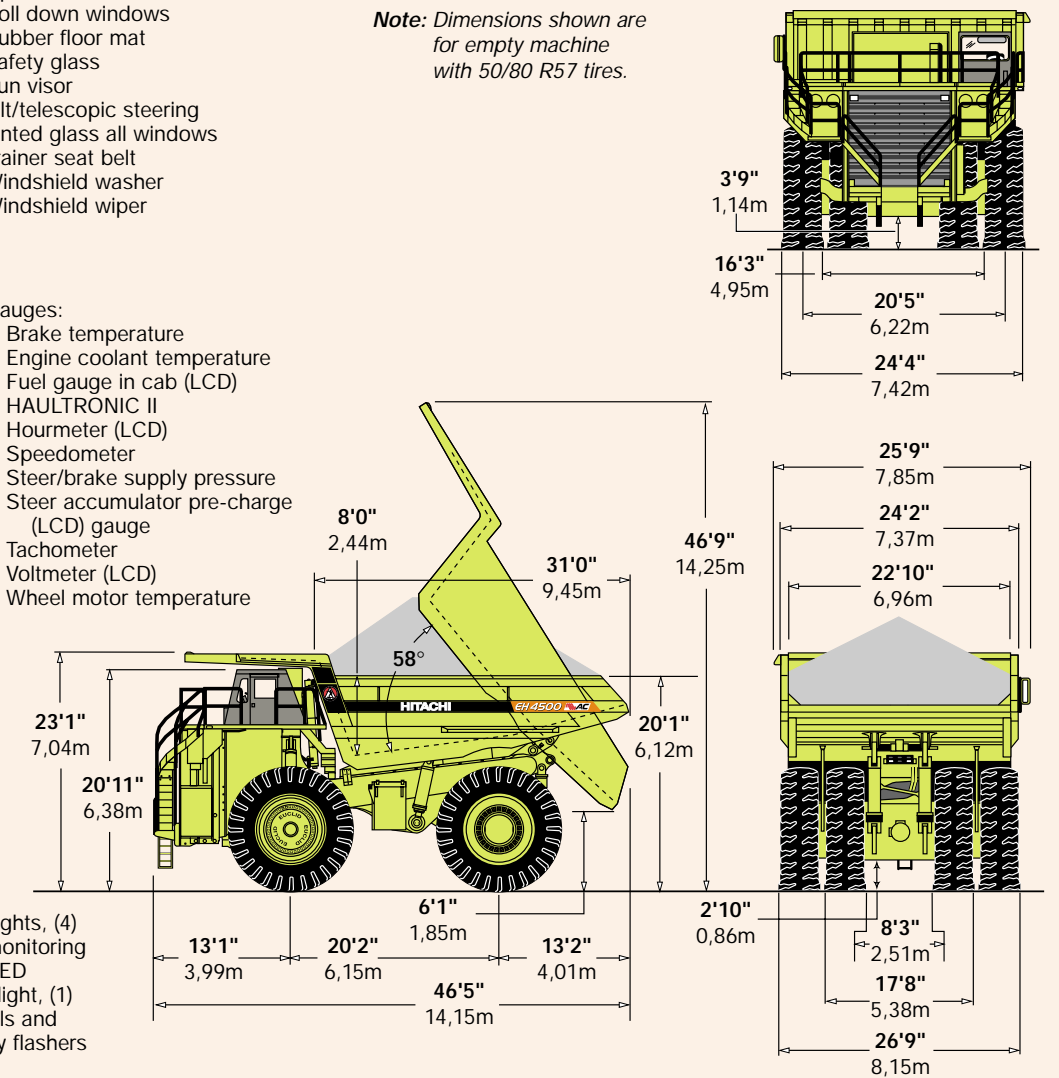



EH4500 AC WHEEL MOTOR

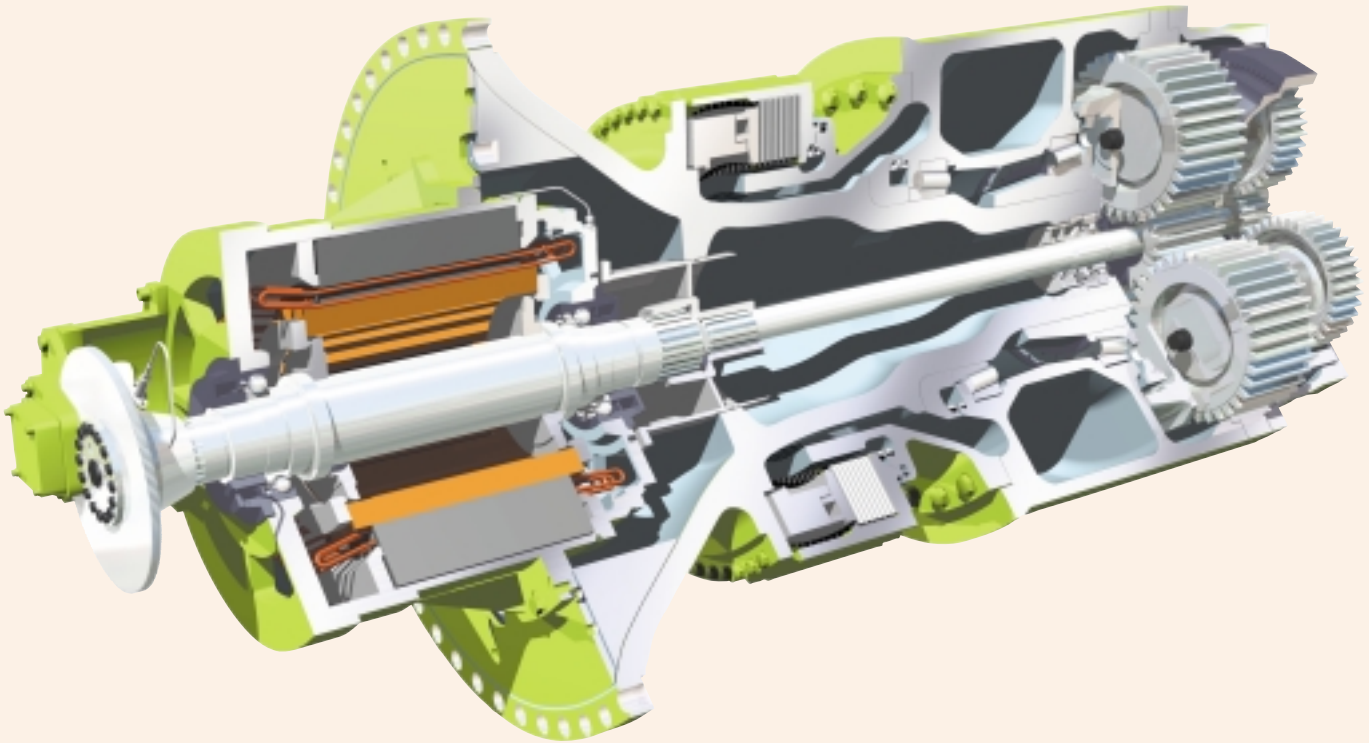

- System efficiency is significantly higher than DC
- Full retarding capability, down to zero speed, equal to or greater than the starting rimpull
- Higher operating speed
- Increased retarding capability reduces brake wear
- AC motors are brushless, and essentially maintenance free

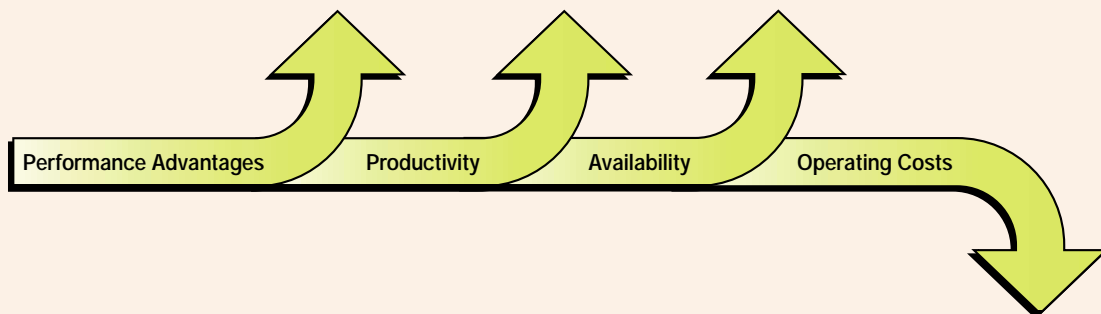

Under our policy of continuous product improvement, we reserve the right to change specifications and design without prior notice. The illustrations do not necessarily show the standard version of the machine.

Hitachi Construction Machinery (America) Corp.
20411 Imperial Valley Dr.
Houston, Texas 77073
281-821-2400
www.hcmacorp.com



FORM NO. EH4500
DATE 7/01
Printed in U.S.A.