

HITACHI

EH 600

Maximum Payload
32,6 Tonne (35.9 Ton)

**Maximum Payload
with Standard Liners**
30,5 Tonne (33.6 Ton)

Maximum GMW
56 911 kg (125,467 lb)

Engine
Volvo TD 122 KFE
Rated Output 297 kW (398 hp)



Specifications: EH600



ENGINE

Volvo TD 122 KFE, four-stroke direct-injected turbocharged diesel engine with charge air cooler and wet, replaceable cylinder liners.

Cold starter: Cold starter boosts fuel injection and incorporates starting element to preheat intake air.

Air filter: Cyclone cleaner, main filter of paper type and catch-all safety filter.

Radiator fan: Extraction fan mounted on engine.

Make	Volvo			
Model	TD 122KFE			
Type	4 Cycle			
Aspiration	Turbocharged			
Gross Power (SAE 1995 @ 2100 rpm)	kW	hp	297	398
Net Power (SAE 1349 @ 2100 rpm)	kW	hp	286	383
No. Cylinders	6			
Bore & Stroke	mm	130 x 150		
	in	5.1 x 5.9		
Displacement	liters	in ³	12,0	1,150
Maximum Torque (SAE 1995) @ 1400 rpm	N•m	lb/ft	1 680	1,239
Starting	Electric			



TRANSMISSION

Transmission: Allison CLT 754. Automatic planetary-type transmission with built-in retarder.

Torque converter: Allison TC 498. Torque converter integral with transmission with lock-up on all gears (except reverse).

Range	Ratio	km/h	mph
1	5,18:1	11	6.8
2	3,19:1	18	11.2
3	2,02:1	28	17.4
4	1,38:1	41	25.5
5	1,00:1	57	35.4
R	4,72:1	12	7.5



DRIVE AXLE

Axle shafts: Fully floating axle shafts with planetary hub reductions.

Ratios	
Differential	2.40:1
Planetary gear	4.94:1
Total reduction, rear axle	11.86:1



TIRES

Standard - Front and Rear **Rim Width**
Bridgestone 18.00-25(32)E3 mm in 330 13

Optional tires, brands and treads available.



BODY CAPACITY

Load volume complies with SAE J/ISO 6483.

	m ³	yd ³
Struck (SAE)	14,6	19.1
Heap 2:1 (SAE)	21,0	27.5



WEIGHTS

	kg	lb
Net Machine Weight	24 305	53,583
Maximum GMW with Std. Tires [18.00-33(32)E3] Including Options, 50% Fuel, Operator & Payload Not to Exceed	56 911	125,467
Maximum Payload	32 606	71,884
Major Options Approximate change in Net Machine Weight: Body Liners, Complete	2 100	4,630
Max. Payload with Body Liners, Complete	30 506	67,254
Weight Distribution	FRONT	REAR
Empty	50%	50%
Loaded	32%	68%



HYDRAULIC SYSTEM

Hoist: One three-stage telescopic cylinder, two stages are double-acting. A hoist stop is built into the cylinder.

Hydraulic system: Load-sensing hydrostatic system. Two engine-driven piston pumps mounted on the engine transmission's power take-off. Common pumps and reservoir for steering and hoist. Steering is always given priority over the hoist system.

Hoist		s	
Raise Time with Load			12
Lower Time			12

Hydraulic System	MPa	psi		
Relief Pressure			19	2,755
Flow	l/min	gpm	189	49.9
At Engine Speed	rps	rpm	35	2,100



BRAKE SYSTEM

Service brakes: Uses dual circuit air-operated drum brakes on all four wheels.

Circuit division: Circuit 1 supplies the front brakes. Circuit 2 supplies the rear brakes.

Parking brake: Separate circuit. Spring-actuated drum brakes on all four wheels.

Compressor Capacity	l/min	gpm		
At	MPa	psi	0,7	101
And	rps	rpm	35	2,100
Pressure Regulator	MPa	psi		
Actuate			0,75	109
Relief	MPa	psi	0,81	117

Brake Area	cm ²	in ²		
Front/Wheel (each)			1 770	274
Rear/Wheel (each)	cm ²	in ²	1 770	274
No. of Reservoirs	3			
Total Volume	l	ft ³	140	4.94

Parking Brake	cm ²	in ²		
Area			7 080	1,097

Retarder:	kW	hp		
Capacity			265	360
At	rps	rpm	35	2,100



STEERING SYSTEM

Load-sensing hydrostatic steering system of closed-center type.

Steering Angle	40°			
Turning Diameters (SAE J/ISO 5010)	m	ft	in	8,0 26'4"
Lock-to-lock turns	3,8			
Steering Cylinders	2			
Bore	mm	in	63,0	2.5
Stroke	mm	in	500,0	19.69
Piston Rod Diameter	mm	in	40,0	1.57
Relief Pressure	MPa	psi	17,5	2,540

Steering cylinders: Double-acting, one for each wheel, mounted between the steering knuckle arm and brackets on the front axle.

Hydraulic pumps: Two engine-driven, variable piston pumps mounted on the engine transmission's power take-off. Priority is always given to the steering system over the hoist system.

Optional, supplementary steering: A supplementary steer pump is activated when the pressure in the system falls below 0,5 MPa 73 psi.



ELECTRICAL SYSTEM

Two 12-volt batteries connected in series.

Voltage	V	24		
Battery capacity	Ah	160		
Alternator	W	1,680		
Starter motor	kW	hp	6,6	9.0



CAB

ROPS-tested and approved steel cab. Cab mounted on rubber pads in the center-of-gravity line. Heat and sound insulated. Heater and defroster. All windows of tinted safety glass.

Operator's seat: Sprung and shock-absorbed with arm rests, head restraint and seat belt. Adjustable to operator's weight. Individual adjustment of both seat and backrest. Seat for instructor.

Sound level in cab max.	dB (A)	78
Operator's seat		ISRI 6000
Number of exits		1

Equipment & Dimensions: EH600



SUSPENSION

Same suspension cylinders on all four wheels.

Front axle: A fabricated box beam A-frame connects the wheels to the machine frame through a well-sealed spherical bearing, and gas-over-oil suspension cylinders. This three-point mounted axle provides excellent oscillation and stability.

Rear axle: Similar to the front axle, the rear suspension utilizes an A-frame structure bolted to the rear axle. The assembly is connected to the main frame by a spherical bearing at the front, and two air-over-oil suspension cylinders in the rear.

When the machine is loaded, the main frame rests on the rear axle for maximum stability.



BODY

Dumper body: Robust body made of hardened and tempered abrasion-resistant steel plate. The longitudinal stiffeners, made of high-grade steel, eliminate stress concentrations and distribute the force from impacts over the entire length of the body. A flat, sloping floor with rugged, uniformly spaced stiffeners ensures high durability.

The body is geometrically optimized to provide a compact yet spacious unit with a low load height and a low center of gravity for efficient loading. Rubber pads between body and frame. Exhaust-heated body.

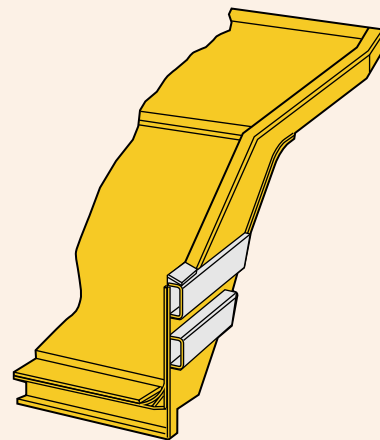

Body		N/mm ²	psi	1 250	181,265
Tensile strength					
Hardness		HB		360-440	
Plate Thickness					
Front & Sides	mm	in	10		0.4
Floor	mm	in	20		0.8



FRAME

Robust construction with beams of carefully selected steel grade with high yield strength. Main beams of all-welded box section with a minimum of joints. Cross members, gussets and brackets have smooth junctions to the frame. Stresses are distributed evenly over the entire frame.



SERVICE CAPACITIES

Service: All vital parts such as engine, transmission, differential and hub reduction are easily accessible for service and maintenance.

	liters	gallons
Crankcase (incl. filters)	37,0	9.8
at change	35,0	9.2
Transmission (incl. filters)	40,0	10.5
at change	30,0	7.9
Rear Axle, Total	60,0	15.9
Cooling System	70,0	18.5
Fuel Tank	550,0	145.0
Hydraulic Tank	75,0	19.8
Hydraulic System (incl. tank)	110,0	29.0

STANDARD EQUIPMENT

BODY EQUIPMENT

Body heating (exhaust) Rock body

HYDRAULIC SYSTEM

Hoist
One three-stage telescoping cylinder, two-stage double-acting

ENGINE AND ELECTRICAL SYSTEM

Alternator
Electric engine inlet air preheater
Gauges/Instruments:
fuel pressure, air (two circuits) pressure, engine oil pressure, transmission oil speedometer
transmission oil pressure transmission oil temperature

Lights:
backup beams
direction indicators
headlights
bright/dim/asymmetric instrument lighting
lights, backup
lights, cab
lights, parking
lights, tail

Pilot lamps for:
body up
bright lights
charging
engine oil pressure
flashers and director indicators
lock-up
parking brake

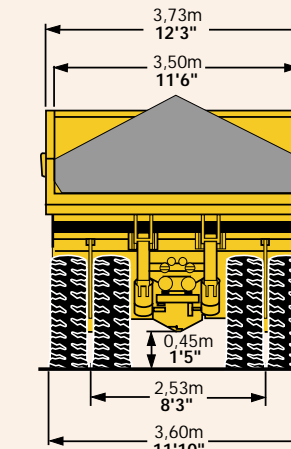
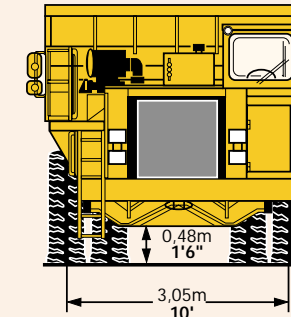

SAFETY AND COMFORT

Air conditioning (R134a)
Anti-theft lock
Cab heating with filtered fresh air intake and defroster
Cigarette lighter and ashtray
Ergonomically designed and adjustable operator's seat
Hazard flashers
Horn
Indicator for air cleaner
Instructor's seat
Rear-view mirrors
Reverse alarm
Rock ejectors
Rubber floor mat
Seat belt, operator
Sun visor
Supplementary steering
Tinted glass
Windshield washers
Windshield wipers

TRANSMISSION

Automatic lock-up
Automatic power shift transmission
Retarder
Torque converter

OPTIONAL EQUIPMENT

Additional working lights
Body liners
Cab guard
Cab heater, auxiliary
Canopy reinforcement
Engine heater
FOPS
Front wheel protection ring
German (TGB) kit
Heated rear-view mirrors
Muffler
Mud flaps, front wheels

Pin plate EEC
Pin plate manufactured in Poland
Rims with wooden protection
Spare rim
Spare wheel
Seat, air ride operator's
Seat, heated operator's
Seat belt, trainer seat
Tool kit
Top extension 190 mm (7.5 in)
Transmission heater

Standard and optional equipment may vary from country to country. Special options provided on request. All specifications are subject to change without notice.

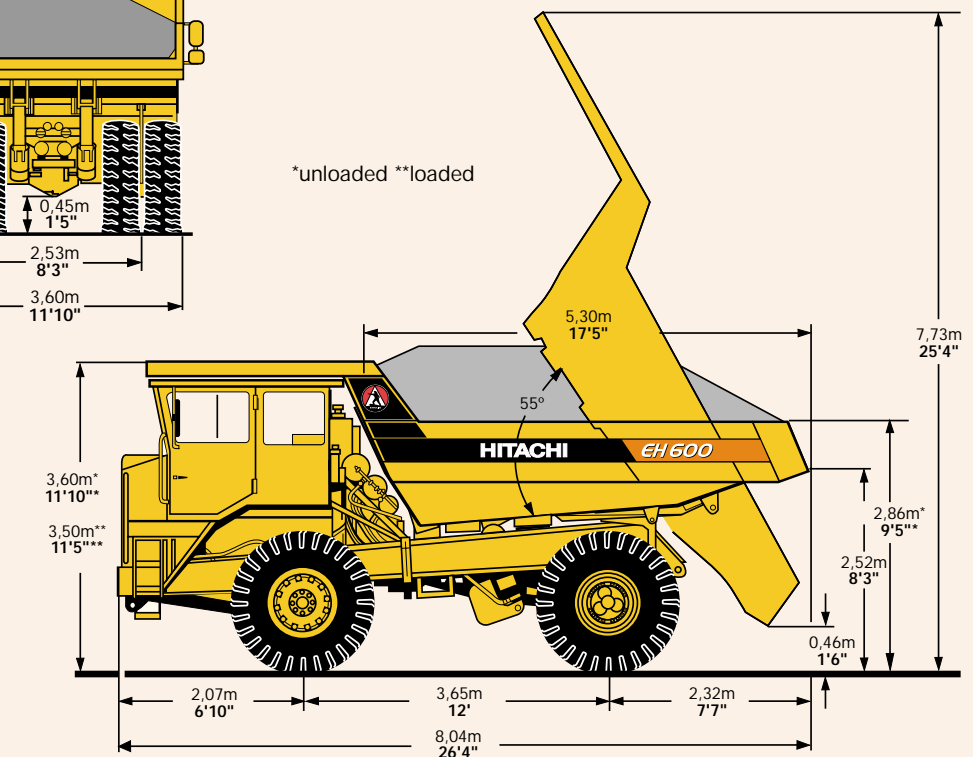
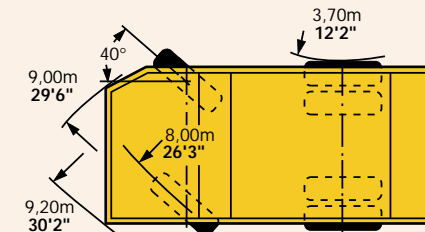

Performance Data: EH600

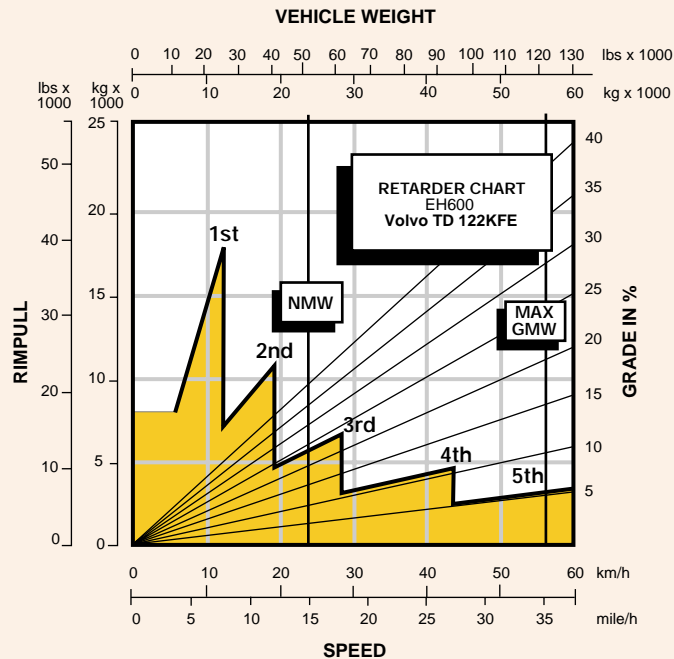
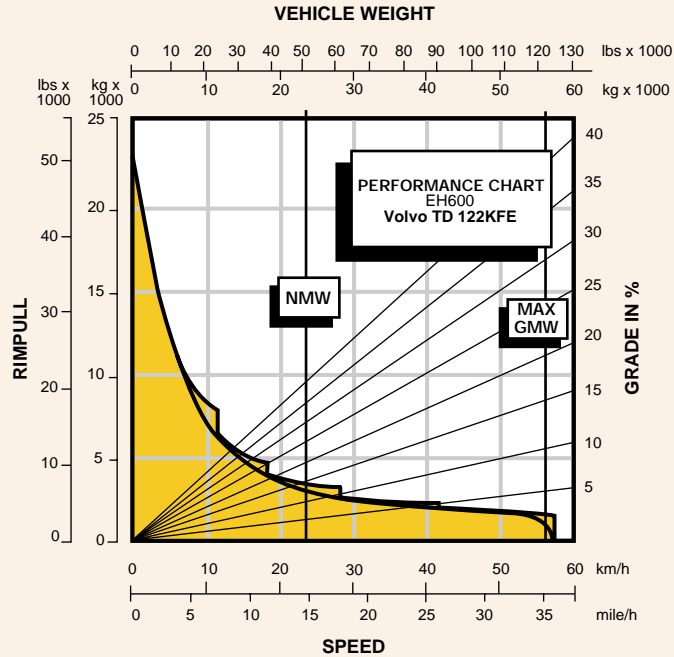

INSTRUCTIONS:

Diagonal lines represent total resistance (Grade % plus rolling resistance %). Charts based on 0% rolling resistance, standard tires and gearing unless otherwise stated.

1. Find the total resistance on diagonal lines on right-hand border
2. Follow the diagonal line downward and intersect the NMW or GMW weight line.
3. From intersection, read horizontally right or left to intersect the performance or retarder curve.
4. Read down for machine speed.

NOTE: Photos and illustrations throughout may show optional equipment.

Under our policy of continuous product improvement, we reserve the right to change specifications and design without prior notice. The illustrations do not necessarily show the standard version of the machine.

