



ZAXIS 17U-2

- Engine Net Power: 14.8 hp (11.0 kW) @ 2,400 rpm
- Operating Weight: 4,173 lb. (1,893 kg)
- Backhoe Bucket: 1.5 cu. ft. (0.04 m³)

ZAXIS 17U-2 SPECIFICATIONS

Engine

| | |
|-----------------------------------|-------------------------------|
| Make | Yanmar |
| Model | 3TNV70 |
| Non-road emission standards | certified to EPA Tier 4 final |
| Displacement | 52 cu. in. (0.85 L) |
| Net power (ISO9249) | 14.8 hp (11.0 kW) @ 2,400 rpm |

Powertrain

Each track independently driven by hydrostatic axial-piston motor connected to two-stage planetary gear-reduction box

Maximum travel speed

| | |
|-------------------|---|
| Low | 1.5 mph (2.4 km/h) |
| High | 2.7 mph (4.3 km/h) |
| Swing speed | 8.9 rpm |
| Swing brake | spring applied, hydraulically released, automatic |

Hydraulics

Open center with two variable-displacement pumps and one fixed-gear pump

Maximum rated flow

| | |
|-------------------|---|
| Piston pump | 2 x 5.1 gpm (2 x 19.2 L/min.) |
| Gear pump | 3.3 gpm (12.5 L/min.) |
| Auxiliary | 8.4 gpm (31.7 L/min.) |
| Controls | hydraulic pilot-operated for boom, arm, bucket, swing, boom swing, blade, travel, and auxiliary functions |

Electrical

| | |
|-------------------------|---------------------|
| Alternator rating | 40 amp |
| Work lights | one mounted on boom |

Undercarriage

Planetary final drive; two-speed axial-piston propel motors

| | |
|---|------------------|
| Tracks, rubber | 9 in. (230 mm) |
| Ground pressure (with rubber track) | 4.1 psi (28 kPa) |

Upperstructure

Rotation

Independent swing boom

| | |
|-------------|---------|
| Left | 70 deg. |
| Right | 50 deg. |

Counterweight

| | |
|----------------------|------------------|
| Standard | 507 lb. (230 kg) |
| Optional extra | 176 lb. (80 kg) |

Tailswing

| | |
|------------------------------------|----------------|
| Standard counterweight | 1 in. (35 mm) |
| Optional extra counterweight | 5 in. (115 mm) |

Front Attachments

Boom

Arm

| | |
|----------------|----------------------|
| Standard | 3 ft. 1 in. (0.93 m) |
| Long | 3 ft. 8 in. (1.13 m) |

Backfill blade width

| | |
|---------------|----------------------|
| Minimum | 3 ft. 3 in. (0.98 m) |
| Maximum | 4 ft. 2 in. (1.28 m) |

Serviceability

Refill Capacities

| | |
|--------------------------------|-------------------|
| Fuel tank | 5.2 gal. (19.5 L) |
| Cooling system | 2.9 qt. (2.7 L) |
| Engine oil (with filter) | 3.3 qt. (3.1 L) |
| Hydraulic tank | 5.3 gal. (20.2 L) |
| Travel gearbox (each) | 0.26 qt. (0.25 L) |

Operating Weights

| | | |
|--|--|---|
| | 3 ft. 1 in. (0.93 m) Standard arm and standard counterweight | 3 ft. 8 in. (1.13 m) Long arm and extra counterweight |
| With full fuel tank and 175-lb. (79 kg) operator | | |
| With rubber track | 4,173 lb. (1893 kg) | 4,364 lb. (1979 kg) |
| With steel track | 4,319 lb. (1959 kg) | 4,508 lb. (2045 kg) |

Working Ranges

| | 3 ft. 1 in. (0.93 m) Standard arm and standard counterweight | 3 ft. 8 in. (1.13 m) Long arm and extra counterweight |
|---------------------------------|--|---|
| A Max. digging height | 11 ft. 8 in. (3.56 m) | 12 ft. (3.66 m) |
| B Max. dumping height | 8 ft. 4 in. (2.53 m) | 8 ft. 8 in. (2.63 m) |
| C Max. digging depth | 7 ft. 1 in. (2.17 m) | 7 ft. 9 in. (2.37 m) |
| D Max. digging reach | 12 ft. 10 in. (3.90 m) | 13 ft. 5 in. (4.08 m) |
| E Min. front swing radius | 5 ft. 1 in. (1.54 m) | 5 ft. 4 in. (1.63 m) |
| F Transport length..... | 11 ft. 9 in. (3.59 m) | 11 ft. 11 in. (3.64 m) |
| Bucket breakout force | 3,597 lb. (16.0 kN) | 3,597 lb. (16.0 kN) |
| Arm breakout force | 2,316 lb. (10.3 kN) | 2,046 lb. (10.3 kN) |

ZAXIS 17U-2

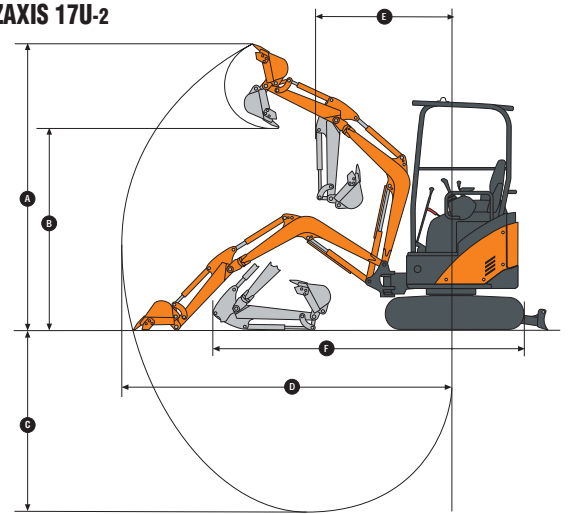

Dimensions

Blade width

| | |
|---------------|----------------------|
| Minimum | 3 ft. 3 in. (0.98 m) |
| Maximum | 4 ft. 2 in. (1.28 m) |

Blade height.....10.2 in. (260 mm)

| | 3 ft. 1 in. (0.93 m) Standard arm, standard counterweight, and rubber track | 3 ft. 8 in. (1.13 m) Long arm extra counter- weight, and rubber track | 3 ft. 1 in. (0.93 m) Standard arm, standard counterweight, and steel track | 3 ft. 8 in. (1.13 m) Long arm extra counter- weight, and steel track |
|---------------------------------|---|---|--|--|
| G Upperstructure width | 3 ft. 3 in. (0.98 m) | 3 ft. 3 in. (0.98 m) | 3 ft. 3 in. (0.98 m) | 3 ft. 3 in. (0.98 m) |
| H Overall height to roof | 7 ft. 10 in. (2.40 m) | 7 ft. 10 in. (2.40 m) | 7 ft. 10 in. (2.40 m) | 7 ft. 10 in. (2.40 m) |
| I Track width | 9 in. (230 mm) | 9 in. (230 mm) | 9 in. (230 mm) | 9 in. (230 mm) |
| J Undercarriage width | | | | |
| Minimum | 3 ft. 2 in. (0.97 m) | 3 ft. 2 in. (0.97 m) | 3 ft. 2 in. (0.97 m) | 3 ft. 2 in. (0.97 m) |
| Maximum | 4 ft. 2 in. (1.28 m) | 4 ft. 2 in. (1.28 m) | 4 ft. 2 in. (1.28 m) | 4 ft. 2 in. (1.28 m) |
| K Ground clearance..... | 6.5 in. (165 mm) | 6.5 in. (165 mm) | 5.7 in. (145 mm) | 5.7 in. (145 mm) |
| L Tail swing radius | 2 ft. 3 in. (675 mm) | 2 ft. 6 in. (755 mm) | 2 ft. 3 in. (675 mm) | 2 ft. 6 in. (755 mm) |
| M Engine cover height | 4 ft. (1.23 m) | 4 ft. (1.23 m) | 4 ft. (1.23 m) | 4 ft. (1.23 m) |
| N Maximum blade lift | 11.2 in. (285 mm) | 11.2 in. (285 mm) | 11.2 in. (285 mm) | 11.2 in. (285 mm) |
| O Maximum blade drop..... | 9.4 in. (240 mm) | 9.4 in. (240 mm) | 9.4 in. (240 mm) | 9.4 in. (240 mm) |
| P Sprocket center | 4 ft. (1.21 m) | 4 ft. (1.21 m) | 3 ft. 11 in. (1.20 m) | 3 ft. 11 in. (1.20 m) |
| Q Track length..... | 5 ft. 2 in. (1.57 m) | 5 ft. 2 in. (1.57 m) | 5 ft. 1 in. (1.55 m) | 5 ft. 1 in. (1.55 m) |
| R Counterweight clearance | 1 ft. 5 in. (435 mm) | 1 ft. 5 in. (435 mm) | 1 ft. 4 in. (415 mm) | 1 ft. 4 in. (415 mm) |

ZAXIS 17U-2

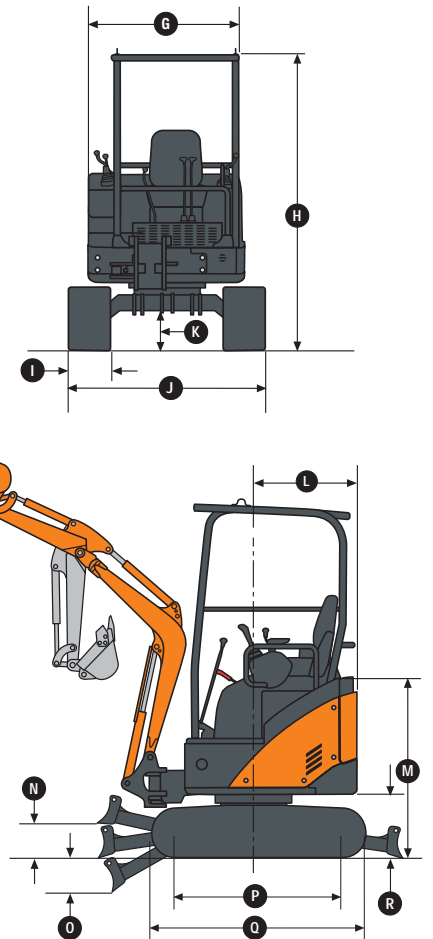

Lift Capacities

| | 3 ft. 1 in. (0.93 m) Standard arm, standard counterweight, and rubber track | 3 ft. 8 in. (1.13 m) Long arm, extra counter- weight, and rubber track | 3 ft. 1 in. (0.93 m) Standard arm, standard Counterweight, and counterweight | 3 ft. 8 in. (1.13 m) Long arm, extra counter- weight, and steel track |
|---|--|--|---|---|
| Over front, blade down (limited by hydraulics)..... | 979 lb. (444 kg) | 963 lb. (437 kg) | 979 lb. (444 kg) | 963 lb. (437 kg) |
| Over side | 500 lb. (227 kg) | 559 lb. (254 kg) | 524 lb. (238 kg) | 583 lb. (264 kg) |

Equipment

Key ● Standard Equipment ▲ Optional or Special Equipment

Engine

- Certified to EPA Tier 4 final non-road emission standards
- Engine coolant to -34°F (-37°C)
- Engine preheater
- Fan guard
- Fuel/water separator
- Full-flow oil filter
- Isolation mounted
- Key start switch with electric fuel shutoff
- Single dry-type air filter
- Under-hood muffler

Hydraulic System

- Auxiliary function foot control
- Auxiliary hydraulic lines with quick-couplers to end of boom
- Auxiliary return-flow selector valve
- Axial-piston swing motor
- Boom-swing foot control
- Excavator-to-backhoe control pattern change valve
- Open center with two variable-displacement pumps and one fixed-gear pump
- Hydraulic pilot-operated controls for boom, arm, bucket, swing, boom swing, blade, travel, and auxiliary functions
- Wet-disc swing brake

Undercarriage

- Hydraulic adjustable variable width
- Planetary final drive

- Propel motor shield
- Two-speed axial-piston propel motors
- Rubber track, 9-in. (230 mm)
- ▲ Steel track, 9-in. (230 mm) with triple semi-grousers
- ▲ Rubber crawler pad, 9-in. (230 mm)

Upperstructure

- 360-degree rotation
- Counterweight, 507 lb. (230 kg)
- Hinged service-access doors
- Independent-swing boom (70-degree left, 50-degree right)
- Toolbox
- ROPS/TOPS/FOPS
- Vandal protection for service doors and seat under cover

Front Attachments

- Arm, 3 ft. 1 in. (0.93 m)
- ▲ Arm, 3 ft. 8 in. (1.13 m)
- Articulation hose shield
- Backfill blade, 3-ft. 3-in. (0.98 m) minimum to 4-ft. 2-in. (1.28 m) maximum
- Boom, 6 ft. (1.82 m)
- Mechanical quick-coupler
- ▲ Augers: Chain drive / Bits / Bit adapters
- ▲ Clamp
- ▲ Quick-coupler buckets: Ditching / Heavy-duty

Operator's Station

- Horn

- Instrumentation lights
- Monitor system: Preheat indicator / Engine oil pressure indicator with alarm / Alternator voltage indicator / Fuel gauge and low fuel-level indicator / Engine coolant temperature gauge and engine coolant high temperature indicator with alarm / Hour meter / Work lights indicator
- Motion alarm with cancel switch
- Work lights switch
- Propel levers
- Two travel speeds
- Seat belt, 2-in. (51 mm), retractable
- Vinyl seat with fore/aft adjustment
- ▲ Front screen

Electrical

- 12-volt accessory outlet
- Alternator, 40 amp
- Low-maintenance battery
- Blade-type multi-fused circuits
- Positive-terminal battery covers

Lights

- Work lights: One mounted on boom

Control Owning and Operating Costs

Customer Personal Service (CPS) is part of Hitachi's proactive, fix-before-fail strategy on machine maintenance that will help control costs, increase profits, and reduce stress. Included in this comprehensive lineup of ongoing programs and services are:

Fluid analysis program – tells you what's going on inside all of your machine's major components so you'll know if there's a problem before you see a decline in performance. Fluid analysis is included in most extended coverage and preventive-maintenance agreements.

Preventive Maintenance (PM) agreements – give you a fixed cost for maintaining a machine for a given period of time. They also help

you avoid downtime by ensuring that critical maintenance work gets done right and on schedule. On-site preventive maintenance service performed where and when you need it helps protect you from the expense of catastrophic failures and lets you avoid waste-disposal hassles.

Extended Coverage Warranty – Extended Coverage Warranty — gives you a fixed cost for machine repairs for a given period of time so you can effectively manage expenses. Whether you work in a severe-service setting, or you just want to spread the risk of doing business, this is a great way to custom-fit coverage to your operation. Choose from engine, powertrain, powertrain plus hydraulics, or full-machine coverage. An Extended Coverage Warranty contract travels well because

it's backed by Hitachi and honored by all Hitachi dealers. What's more, Extended Coverage Warranty can be transferred if you sell or trade your machine, so it adds value at trade-in. For specific Extended Coverage Warranty details, please contact your Hitachi dealer. There may be a transfer fee if application changes.

Customer Support Advisors (CSAs) – the CSA program lends a personal quality to Customer Personal Service (CPS). Certified CSAs have the knowledge and skills for helping make important decisions on machine maintenance and repair. Their mission is to help you implement a plan that's right for your business and take the burden of machine maintenance off your shoulders.

Net engine power is with standard equipment including air cleaner, exhaust system, alternator, and cooling fan at test conditions per ISO9249. No derating is required up to 6,600-ft. (2000 m) altitude. Specifications and design subject to change without notice. Wherever applicable, specifications are in accordance with SAE standards. Except where otherwise noted, these specifications are based on a canopy unit with 17.7-in. (450 mm) 1.5-cu.-ft. (0.04 m³) bucket; 9-in. (230 mm) rubber track; 507-lb. (230 kg) counterweight; full fuel tank; and 175-lb. (79 kg) operator. Lift capacities shown are for base machine above with mechanical quick-coupler, less bucket.

HITACHI