

ZAXIS | DASH-5 PRODUCTION-CLASS EXCAVATORS

ZX670LC-5

345 kW (463 hp)

ZX670LC



HITACHI

Engine		ZX670LC-5	
Manufacturer and Model	Isuzu 6WGI-iT4		
Non-Road Emission Standard	EPA Interim Tier 4/EU Stage IIIB		
Net Rated Power (ISO 9249)	345 kW (463 hp) @ 1,800 rpm		
Cylinders	6		
Displacement	15.7L (957 cu. in.)		
Off-Level Capacity	70% (35 deg.)		
Aspiration	Turbocharged, air-to-air charge-air cooler		
Cooling		2 cool-on-demand hydraulic-driven, suction-type fans with remote-mounted drives	
Powertrain		2-speed propel with automatic shift	
Maximum Travel Speed			
Low	3.6 km/h (2.2 mph)		
High	5.2 km/h (3.2 mph)		
Drawbar Pull	46 115 kg (101,666 lb.)		
Hydraulics			
Open center, load sensing			
Main Pumps		2 variable-displacement pumps	
Maximum Rated Flow	489 L/m (129 gpm) x 2		
Pilot Pump		One gear	
Maximum Rated Flow	30 L/m (7.9 gpm)		
Pressure Setting	3900 kPa (566 psi)		
System Operating Pressure			
Circuits			
Implement	31 900 kPa (4,627 psi)		
Travel	34 300 kPa (4,975 psi)		
Swing	29 400 kPa (4,264 psi)		
Power Boost	34 300 kPa (4,975 psi)		
Controls		Pilot levers, short-stroke, low-effort hydraulic pilot controls with shutoff lever	
Cylinders			
	Bore	Rod Diameter	Stroke
Boom (2)	191 mm (7.5 in.)	130 mm (5.1 in.)	1806 mm (71 in.)
Arm (1)	201 mm (7.9 in.)	140 mm (5.5 in.)	2164 mm (85 in.)
Bucket (1)	180 mm (7.1 in.)	130 mm (5.1 in.)	1555 mm (61 in.)
Electrical			
Number of Batteries (12 volt)	2		
Battery Capacity	500 CCA		
Alternator Rating	50 amp		
Work Lights	5 halogen (1 mounted on frame, 2 mounted on boom, and 2 mounted on top of cab)		
Undercarriage			
Rollers (each side)			
Carrier	3		
Track	8		
Shoes, Triple Semi-Grousers (each side)	47		
Track			
Adjustment	Hydraulic		
Guides	Front and center		
Chain	Sealed and lubricated		

DASH-5

Ground Pressure		ZX670LC-5
650-mm (26 in.) Triple Semi-Grouser Shoes		93.8 kPa (13.6 psi)
750-mm (30 in.) Triple Semi-Grouser Shoes		82.7 kPa (12 psi)
900-mm (36 in.) Triple Semi-Grouser Shoes		69.6 kPa (10.1 psi)
Swing Mechanism		
Swing Speed		9.1 rpm
Swing Torque		194 000 Nm (143,087 lb.-ft.)
Serviceability		
Refill Capacities		
Fuel Tank		900L (238 gal.)
Cooling System		70L (18.5 gal.)
Engine Oil with Filter		57L (15.1 gal.)
Hydraulic Tank		380L (100.4 gal.)
Hydraulic System		750L (198.1 gal.)
Gearbox		
Swing (each)		10.5L (11.1 qt.)
Travel (each)		16L (16.9 qt.)
Pump Drive		6.2L (6.6 qt.)
Operating Weights		
With full fuel tank; 79-kg (175 lb.) operator; 3.09-m ³ (4.04 cu. yd.), 1370-mm (54 in.), 3126-kg (6,892 lb.) bucket; 4.2-m (13 ft. 9 in.) arm; 10 400-kg (22,928 lb.) counterweight; and 900-mm (36 in.) double-bar grouser shoes		
SAE Operating Weight		71 688 kg (158,045 lb.)
Optional Components		
Undercarriage w/ Double-Bar Grouser Shoes		
650 mm (26 in.)		26 620 kg (58,687 lb.)
750 mm (30 in.)		27 240 kg (60,054 lb.)
900 mm (36 in.)		28 180 kg (62,126 lb.)
One-Piece Boom (with arm cylinder)		
7.8 m (25 ft. 7 in.)		6550 kg (14,440 lb.)
6.8-m (22 ft. 4 in.) Mass Excavating		6110 kg (13,470 lb.)
Arm with Bucket Cylinder and Linkage		
3.6 m (11 ft. 10 in.)		3620 kg (7,981 lb.)
4.2 m (13 ft. 9 in.)		3930 kg (8,664 lb.)
5.3 m (17 ft. 5 in.)		3620 kg (7,981 lb.)
2.9-m (9 ft. 6 in.) Mass Excavating		3820 kg (8,422 lb.)
Boom-Lift Cylinders (2), Total Weight		
3.09-m ³ (4.04 cu. yd.), 1370-mm (54 in.)		1110 kg (2,447 lb.)
Heavy-Duty High-Capacity Bucket		3126 kg (6,892 lb.)
Counterweight, Standard		10 400 kg (22,928 lb.)

Operating Dimensions		ZX670LC-5			
Arm Length		3.6 m (11 ft. 10 in.) w/ 7.8-m (25 ft. 7 in.) Boom	4.2 m (13 ft. 9 in.) w/ 7.8-m (25 ft. 7 in.) Boom	5.3 m (17 ft. 5 in.) w/ 7.8-m (25 ft. 7 in.) Boom	2.9-m (9 ft. 6 in.) Mass Excavating w/ 6.8-m (22 ft. 4 in.) Mass-Excavating Boom
Arm Digging Force					
SAE		247 kN (55,528 lb.)	224 kN (50,357 lb.)	192 kN (43,163 lb.)	297 kN (66,768 lb.)
ISO		255 kN (57,326 lb.)	231 kN (51,931 lb.)	196 kN (44,063 lb.)	306 kN (68,792 lb.)
Bucket Digging Force					
SAE		290 kN (65,195 lb.)	290 kN (65,195 lb.)	245 kN (55,078 lb.)	332 kN (74,637 lb.)
ISO		324 kN (72,838 lb.)	324 kN (72,838 lb.)	277 kN (62,272 lb.)	369 kN (82,954 lb.)
A	Maximum Reach	13.25 m (43 ft. 6 in.)	13.85 m (45 ft. 5 in.)	14.74 m (48 ft. 4 in.)	11.81 m (38 ft. 9 in.)
A'	Maximum Reach at Ground Level	13 m (42 ft. 8 in.)	13.61 m (44 ft. 8 in.)	14.51 m (47 ft. 7 in.)	11.50 m (37 ft. 9 in.)
B	Maximum Digging Depth	8.53 m (28 ft.)	9.15 m (30 ft.)	10.03 m (32 ft. 11 in.)	7.12 m (23 ft. 4 in.)
B'	Maximum Digging Depth at 2.44-m (8 ft.) Flat Bottom	8.40 m (27 ft. 7 in.)	9.03 m (29 ft. 8 in.)	9.92 m (32 ft. 7 in.)	6.97 m (22 ft. 10 in.)
C	Maximum Cutting Height	11.92 m (39 ft. 1 in.)	12.24 m (40 ft. 2 in.)	12.65 m (41 ft. 6 in.)	11.90 m (39 ft. 1 in.)
D	Maximum Dumping Height	8.05 m (26 ft. 5 in.)	8.33 m (27 ft. 4 in.)	9.17 m (30 ft. 1 in.)	7.33 m (24 ft. 1 in.)
E	Minimum Swing Radius	5.78 m (19 ft.)	5.76 m (18 ft. 11 in.)	5.60 m (18 ft. 4 in.)	5.24 m (17 ft. 2 in.)
F	Maximum Vertical Wall	7.38 m (24 ft. 3 in.)	8.18 m (26 ft. 10 in.)	9.53 m (31 ft. 3 in.)	5.28 m (17 ft. 4 in.)

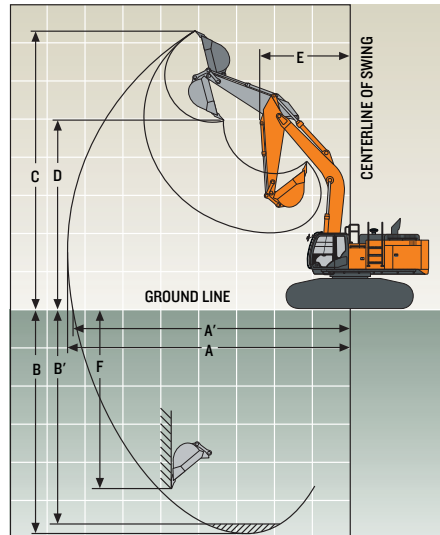

DASH-5

Machine Dimensions

ZX670LC-5

A Overall Length w/ Arm	
3.6 m (11 ft. 10 in.)	13.40 m (44 ft.)
4.2 m (13 ft. 9 in.)	13.40 m (44 ft.)
5.3 m (17 ft. 5 in.)	13.06 m (42 ft. 10 in.)
2.9-m (9 ft. 6 in.) Mass Excavating with Mass-Excavating Boom	12.42 m (40 ft. 9 in.)
B Overall Height w/ Arm	
3.6 m (11 ft. 10 in.)	4.46 m (14 ft. 8 in.)
4.2 m (13 ft. 9 in.)	4.98 m (16 ft. 4 in.)
5.3 m (17 ft. 5 in.)	5.28 m (17 ft. 4 in.)
2.9-m (9 ft. 6 in.) Mass Excavating with Mass-Excavating Boom	4.96 m (16 ft. 3 in.)
C Rear-End Length/Swing Radius	3.91 m (12 ft. 10 in.)
D Distance Between Idler/Sprocket Centerline	4.60 m (15 ft. 1 in.)
E Undercarriage Length	5.84 m (19 ft. 2 in.)
F Counterweight Clearance	1.53 m (5 ft.)
G Upperstructure Width	4.09 m (13 ft. 5 in.)
H Cab Height	3.66 m (11 ft. 4 in.)
I Track Width w/ Double-Bar Grouser Shoes	650 mm (26 in.) / 750 mm (30 in.) / 900 mm (36 in.)
J Gauge Width	
Operating Position	3.30 m (10 ft. 10 in.)
Transport Position	2.82 m (9 ft. 3 in.)
K Ground Clearance	0.86 m (34 in.)
L Overall Width w/ 900-mm (36 in.) Double-Bar Grouser Shoes	
Operating Position	4.19 m (13 ft. 9 in.)
Transport Position	3.73 m (12 ft. 3 in.)

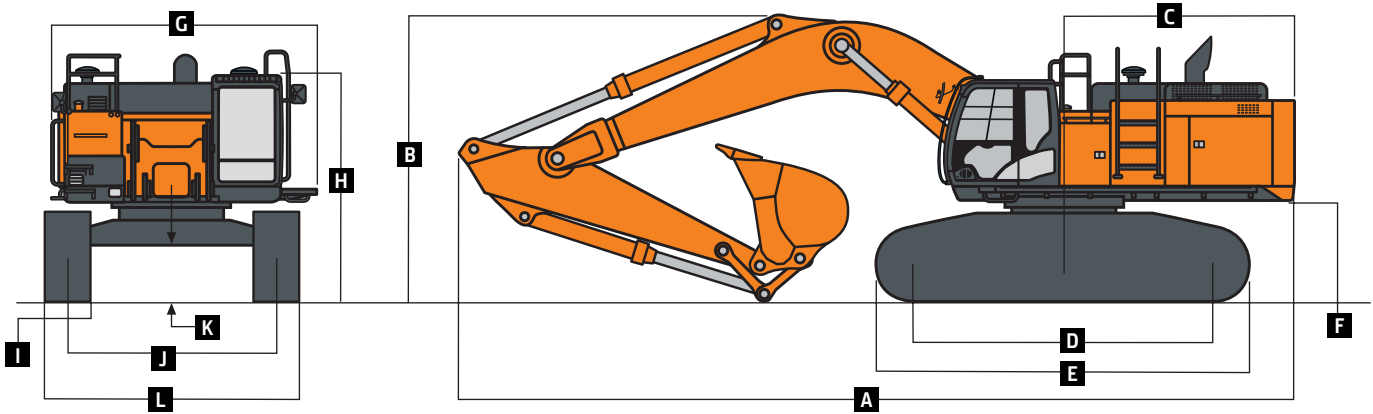

Operating Dimensions		ZX670LC-5		
Base Machine (without front attachment and side frame)*	Length 5.22 m (17 ft. 2 in.)	Height 3.32 m (10 ft. 11 in.)	Overall Width 3.39 m (11 ft. 1 in.)	Weight 20 100 kg (44,313 lb.)
Side Frame**				
650-mm (26 in.) Shoe Width	5.84 m (19 ft. 2 in.)	1.45 m (4 ft. 9 in.)	1.19 m (3 ft. 11 in.)	10 300 kg (22,708 lb.)
750-mm (30 in.) Shoe Width	5.84 m (19 ft. 2 in.)	1.45 m (4 ft. 9 in.)	1.24 m (4 ft. 1 in.)	10 600 kg (23,369 lb.)
900-mm (36 in.) Shoe Width	5.84 m (19 ft. 2 in.)	1.45 m (4 ft. 9 in.)	1.32 m (4 ft. 4 in.)	11 100 kg (24,471 lb.)
Counterweight, Standard	3.36 m (11 ft.)	1.55 m (5 ft. 1 in.)	0.59 m (23 in.)	11 100 kg (24,471 lb.)
Boom				
6.8 m (22 ft. 4 in.)	7.14 m (23 ft. 5 in.)	2.51 m (8 ft. 3 in.)	1.39 m (4 ft. 7 in.)	6110 kg (13,470 lb.)
7.8 m (25 ft. 7 in.)	8.13 m (26 ft. 8 in.)	2.33 m (7 ft. 8 in.)	1.39 m (4 ft. 7 in.)	6550 kg (14,440 lb.)
Arm				
2.9 m (9 ft. 6 in.)	4.37 m (14 ft. 4 in.)	1.69 m (5 ft. 7 in.)	0.80 m (31 in.)	3620 kg (7,981 lb.)
3.6 m (11 ft. 10 in.)	5.11 m (16 ft. 9 in.)	1.44 m (4 ft. 9 in.)	0.80 m (31 in.)	3620 kg (7,981 lb.)
4.2 m (13 ft. 9 in.)	5.71 m (18 ft. 9 in.)	1.39 m (4 ft. 7 in.)	0.80 m (31 in.)	3930 kg (8,664 lb.)
5.3 m (17 ft. 1 in.)	6.73 m (22 ft. 1 in.)	1.26 m (4 ft. 2 in.)	0.80 m (31 in.)	3620 kg (7,981 lb.)
Less Arm and Counterweight	6.24 m (20 ft. 6 in.)	4.23 m (13 ft. 11 in.) / 3.76 m (12 ft. 4 in.) without exhaust stack	3.48 m (11 ft. 5 in.) with 650-mm (26 in.) shoes / 3.58 m (11 ft. 9 in.) with 750-mm (30 in.) shoes	42 900 kg (94,578 lb.) with 650-mm (26 in.) shoes / 43 300 kg (95,460 lb.) with 750-mm (30 in.) shoes

*Steps on the track frame and the side hydraulic oil tank, handrails on the upper battery box, upper fuel tank, and the side hydraulic oil tank must be removed to comply with the overall width dimensions above

**The dimensions and the weights indicate those of one side frame.

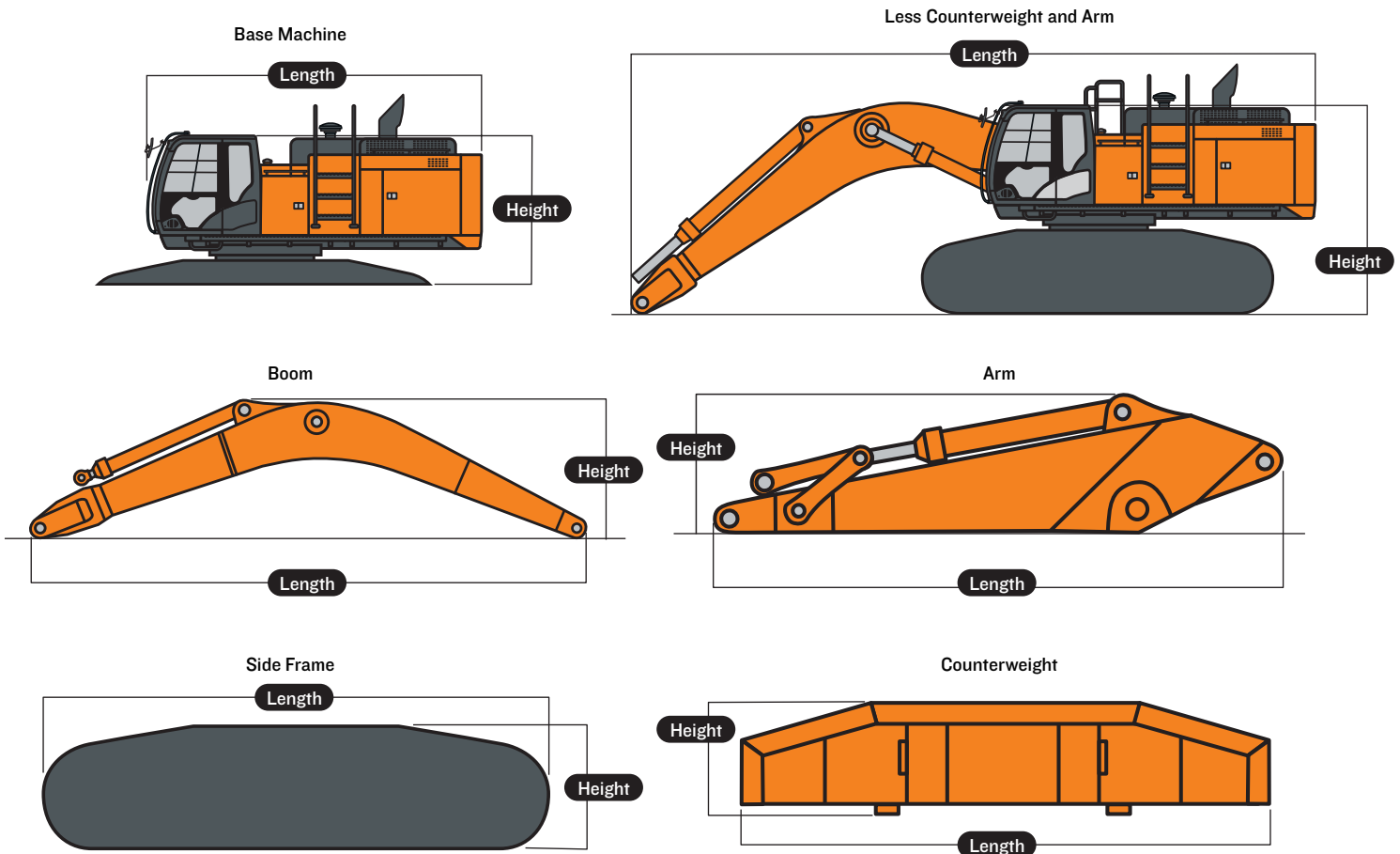

DASH-5

Lift Charts

ZX670LC-5

Boldface type indicates hydraulically limited capacity; lightface type indicates stability-limited capacities, in kg (lb.). Ratings at bucket lift hook; machine equipped with standard gauge and situated on firm, uniform supporting surface. Total load includes weight of cables, hook, etc. Figures do not exceed 87 percent of hydraulic capacities or 75 percent of weight needed to tip machine. All lift capacities are based on ISO 10567 (with power boost).

Load Point Height	3.0 m (10 ft.)		4.5 m (15 ft.)		6.0 m (20 ft.)		7.5 m (25 ft.)		9.0 m (30 ft.)		10.5 m (35 ft.)	
Horizontal Distance from Centerline of Rotation	Over Front	Over Side	Over Front	Over Side	Over Front	Over Side	Over Front	Over Side	Over Front	Over Side	Over Front	Over Side
With 2.5-m ³ (3.3 cu. yd.) bucket, 4.2-m (13 ft. 9 in.) arm, 7.8-m (25 ft. 7 in.) boom, and 650-mm (26 in.) double-bar grouser shoes												
7.5 m (25 ft.)									10 877	10 877		
									(23,789)	(23,789)		
6.0 m (20 ft.)									11 695	11 695	10 074	8822
									(25,455)	(25,455)	(20,249)	(18,828)
4.5 m (15 ft.)					18 419	18 419	14 846	14 846	12 770	11 434	11 489	8600
					(39,595)	(39,595)	(32,081)	(32,081)	(27,710)	(24,562)	(25,022)	(18,394)
3.0 m (10 ft.)					21 775	21 060	16 786	14 767	13 935	10 914	12 146	8297
					(46,868)	(45,389)	(36,258)	(31,793)	(30,192)	(23,454)	(26,076)	(17,780)
1.5 m (5 ft.)					24 280	19 840	18 421	14 015	14 970	10 443	11 847	8011
					(52,394)	(42,717)	(39,817)	(30,161)	(32,415)	(22,442)	(25,435)	(17,176)
Ground Line			14 147	14 147	25 552	19 118	19 474	13 480	14 937	10 081	11 611	7789
			(32,798)	(32,798)	(55,264)	(41,112)	(42,128)	(28,992)	(32,099)	(21,662)	(24,941)	(16,710)
-1.5 m (-5 ft.)	10 795	10 795	19 888	19 888	25 665	18 795	19 742	13 178	14 702	9864	11 488	7673
	(24,434)	(24,434)	(45,601)	(45,601)	(55,570)	(40,387)	(42,409)	(28,333)	(31,598)	(21,196)	(24,701)	(16,485)
-3.0 m (-10 ft.)	17 778	17 778	27 898	27 898	24 708	18 764	19 274	13 097	14 647	9813		
	(40,167)	(40,167)	(63,882)	(63,882)	(53,469)	(40,316)	(41,640)	(28,162)	(31,502)	(21,107)		
-4.5 m (-15 ft.)	26 090	26 090	29 339	29 339	22 538	18 985	17 625	13 238	13 567	9987		
	(59,144)	(59,144)	(63,392)	(63,392)	(48,598)	(40,816)	(37,853)	(28,498)	(28,680)	(21,554)		
-6.0 m (-20 ft.)			23 967	23 967	18 551	18 551	13 914	13 697				
			(51,241)	(51,241)	(39,462)	(39,462)	(28,969)	(28,969)				
With 3.5-m ³ (4.6 cu. yd.) bucket, 2.9-m (9 ft. 6 in.) BE arm, 6.8-m (22 ft. 4 in.) BE boom, and 650-mm (26 in.) double-bar grouser shoes												
7.5 m (25 ft.)							14 395	14 395				
							(31,612)	(31,612)				
6.0 m (20 ft.)					17 527	17 527	15 276	15 276				
					(37,885)	(37,885)	(33,224)	(33,224)				
4.5 m (15 ft.)					20 472	20 472	16 699	15 012	14 652	10 731		
					(44,111)	(44,111)	(36,197)	(32,260)	(31,942)	(22,921)		
3.0 m (10 ft.)					23 433	20 710	18 261	14 337	15 341	10 437		
					(50,516)	(44,580)	(39,522)	(30,822)	(32,915)	(22,377)		
1.5 m (5 ft.)					25 431	19 776	19 475	13 778	15 019	10 138		
					(54,940)	(42,529)	(42,140)	(29,614)	(32,245)	(21,754)		
Ground Line			26 021	19 288	19 945	13 427	14 832	9965				
			(56,317)	(41,441)	(43,040)	(28,854)	(31,876)	(21,412)				
-1.5 m (-5 ft.)			33 521	31 688	25 148	19 170	19 302	13 325				
			(72,778)	(67,856)	(54,427)	(41,173)	(41,640)	(28,645)				
-3.0 m (-10 ft.)	34 294	34 294	29 559	29 559	22 510	19 382	16 667	13 551				
	(77,983)	(77,983)	(63,977)	(63,977)	(48,496)	(41,653)	(35,284)	(29,217)				
-4.5 m (-15 ft.)			22 634	22 634	16 493	16 493						
			(48,277)	(48,277)	(34,298)	(34,298)						
With 2.5-m ³ (3.3 cu. yd.) bucket, 4.2-m (13 ft. 9 in.) arm, 7.8-m (25 ft. 7 in.) boom, and 750-mm (30 in.) double-bar grouser shoes												
7.5 m (25 ft.)									10 877	10 877		
									(23,789)	(23,789)		
6.0 m (20 ft.)									11 695	11 695	10 074	8879
									(25,455)	(25,455)	(20,249)	(18,952)
4.5 m (15 ft.)					18 419	18 419	14 846	14 846	12 770	11 503	11 489	8657
					(39,595)	(39,595)	(32,081)	(32,081)	(27,710)	(24,712)	(25,022)	(18,518)
3.0 m (10 ft.)					21 775	21 178	16 786	14 854	13 935	10 983	12 146	8354
					(46,868)	(45,643)	(36,258)	(31,981)	(30,192)	(23,603)	(26,249)	(17,903)
1.5 m (5 ft.)					24 280	19 958	18 421	14 102	14 970	10 512	11 927	8068
					(52,394)	(42,971)	(39,817)	(30,349)	(32,415)	(22,591)	(25,608)	(17,300)
Ground Line			14 147	14 147	25 552	19 236	19 474	13 567	15 035	10 150	11 691	7846
			(32,798)	(32,798)	(55,264)	(41,112)	(42,128)	(28,992)	(32,311)	(21,662)	(25,114)	(16,710)
-1.5 m (-5 ft.)	10 795	10 795	19 888	19 888	25 665	18 912	19 798	13 265	14 800	9933	11 568	7730
	(24,434)	(24,434)	(45,601)	(45,601)	(55,570)	(40,642)	(42,681)	(28,521)	(31,810)	(21,346)	(24,874)	(16,608)
-3.0 m (-10 ft.)	17 778	17 778	27 898	27 898	24 708	18 882	19 274	13 184	14 745	9882		
	(40,167)	(40,167)	(63,882)	(63,882)	(53,469)	(40,570)	(41,640)	(28,350)	(31,713)	(21,256)		
-4.5 m (-15 ft.)	26 090	26 090	29 339	29 339	22 538	19 103	17 625	13 325	13 567	10 056		
	(59,144)	(59,144)	(63,392)	(63,392)	(48,598)	(41,070)	(37,853)	(28,686)	(28,680)	(21,703)		
-6.0 m (-20 ft.)			23 967	23 967	18 551	18 551	13 914	13 784				
			(51,241)	(51,241)	(39,462)	(39,462)	(28,969)	(28,969)				

Lift Charts

ZX670LC-5

Boldface type indicates hydraulically limited capacity; **lightface** type indicates stability-limited capacities, in kg (lb.). Ratings at bucket lift hook; machine equipped with standard gauge and situated on firm, uniform supporting surface. Total load includes weight of cables, hook, etc. Figures do not exceed 87 percent of hydraulic capacities or 75 percent of weight needed to tip machine. All lift capacities are based on ISO 10567 (with power boost).

Load Point Height	3.0 m (10 ft.)		4.5 m (15 ft.)		6.0 m (20 ft.)		7.5 m (25 ft.)		9.0 m (30 ft.)		10.5 m (35 ft.)	
Horizontal Distance from Centerline of Rotation	Over Front	Over Side	Over Front	Over Side	Over Front	Over Side	Over Front	Over Side	Over Front	Over Side	Over Front	Over Side
With 2.9-m ³ (3.8 cu. yd.) bucket, 3.6-m (11 ft. 10 in.) arm, 7.8-m (25 ft. 7 in.) boom, and 900-mm (36 in.) double-bar grouser shoes												
7.5 m (25 ft.)									11 737 (25,696)	11 737 (25,696)		
6.0 m (20 ft.)							13 984 (30,277)	13 984 (30,277)	12 459 (27,118)	11 908 (25,550)		
4.5 m (15 ft.)					19 903 (42,762)	19 903 (42,762)	15 769 (34,065)	15 613 (33,620)	13 440 (29,162)	11 455 (24,611)	12 043 (23,250)	8611 (18,398)
3.0 m (10 ft.)					23 023 (49,548)	20 966 (45,200)	17 563 (37,932)	14 793 (31,856)	14 488 (31,388)	10 978 (23,595)	12 293 (26,380)	8368 (17,930)
1.5 m (5 ft.)					25 061 (54,098)	19 939 (42,929)	18 974 (41,012)	14 126 (30,405)	15 369 (33,275)	10 560 (22,698)	12 038 (25,851)	8128 (17,432)
Ground Line			12 940 (30,246)	12 940 (30,246)	25 788 (55,807)	19 410 (41,737)	19 740 (42,704)	13 687 (29,442)	15 211 (32,695)	10 260 (22,052)	11 861 (25,491)	7961 (17,093)
-1.5 m (-5 ft.)			21 022 (48,226)	21 022 (48,226)	25 394 (55,010)	19 236 (41,334)	19 730 (42,682)	13 479 (28,984)	15 050 (32,358)	10 111 (21,738)		
-3.0 m (-10 ft.)	20 323 (45,939)	20 323 (45,939)	31 007 (67,288)	31 007 (67,288)	23 941 (51,811)	19 319 (41,514)	18 793 (40,564)	13 487 (29,012)	14 834 (31,798)	10 147 (21,850)		
-4.5 m (-15 ft.)	30 660 (69,671)	30 660 (69,671)	27 015 (58,346)	27 015 (58,346)	21 158 (45,545)	19 649 (42,258)	16 490 (35,230)	13 739 (29,603)				
-6.0 m (-20 ft.)			20 645 (43,853)	20 645 (43,853)	16 030 (33,647)	16 030 (33,647)						
With 2.5-m ³ (3.3 cu. yd.) bucket, 4.2-m (13 ft. 9 in.) arm, 7.8-m (25 ft. 7 in.) boom, and 900-mm (36 in.) double-bar grouser shoes												
7.5 m (25 ft.)									10 880 (23,800)	10 880 (23,800)		
6.0 m (20 ft.)									11 700 (25,500)	11 700 (25,500)	10 070 (20,300)	9030 (19,300)
4.5 m (15 ft.)					18 420 (39,600)	18 420 (39,600)	14 850 (32,100)	14 850 (32,100)	12 770 (27,700)	11 690 (25,100)	11 490 (22,500)	8810 (18,900)
3.0 m (10 ft.)					21 780 (46,900)	21 500 (46,300)	16 790 (36,300)	15 090 (32,500)	13 940 (30,200)	11 170 (24,000)	12 150 (26,400)	8510 (18,200)
1.5 m (5 ft.)					24 280 (52,400)	20 280 (43,700)	18 420 (39,800)	14 340 (30,900)	14 970 (32,400)	10 700 (23,000)	12 140 (26,100)	8220 (17,600)
Ground Line			14 150 (32,800)	14 150 (32,800)	25 550 (55,300)	19 560 (42,100)	19 470 (42,100)	13 800 (29,700)	15 300 (32,900)	10 340 (22,200)	11 900 (25,600)	8000 (17,200)
-1.5 m (-5 ft.)	10 800 (24,400)	10 800 (24,400)	19 890 (45,600)	19 890 (45,600)	25 670 (55,600)	19 230 (41,300)	19 800 (42,800)	13 500 (29,000)	15 060 (32,400)	10 120 (21,800)	11 780 (25,300)	7890 (16,900)
-3.0 m (-10 ft.)	17 780 (40,200)	17 780 (40,200)	27 900 (63,900)	27 900 (63,900)	24 710 (53,500)	19 200 (41,300)	19 270 (41,600)	13 420 (28,900)	15 010 (32,300)	10 070 (21,700)		
-4.5 m (-15 ft.)	26 090 (59,100)	26 090 (59,100)	29 340 (63,400)	29 340 (63,400)	22 540 (48,600)	19 420 (41,800)	17 630 (37,900)	13 560 (29,200)	13 570 (28,700)	10 240 (22,100)		
-6.0 m (-20 ft.)			23 970 (51,200)	23 970 (51,200)	18 550 (39,500)	18 550 (39,500)	13 910 (29,000)	13 910 (29,000)				

DASH-5

Lift Charts

ZX670LC-5

Boldface type indicates hydraulically limited capacity; lightface type indicates stability-limited capacities, in kg (lb.). Ratings at bucket lift hook; machine equipped with standard gauge and situated on firm, uniform supporting surface. Total load includes weight of cables, hook, etc. Figures do not exceed 87 percent of hydraulic capacities or 75 percent of weight needed to tip machine. All lift capacities are based on ISO 10567 (with power boost).

Load Point Height	3.0 m (10 ft.)		4.5 m (15 ft.)		6.0 m (20 ft.)		7.5 m (25 ft.)		9.0 m (30 ft.)		10.5 m (35 ft.)	
Horizontal Distance from Centerline of Rotation	Over Front	Over Side	Over Front	Over Side	Over Front	Over Side	Over Front	Over Side	Over Front	Over Side	Over Front	Over Side
With 2-m ³ (2.6 cu. yd.) bucket, 5.3-m (17 ft. 5 in.) arm, 7.8-m (25 ft. 7 in.) boom, and 900-mm (36 in.) double-bar grouser shoes												
9.0 m (30 ft.)											6009	6009
											(11,573)	(11,573)
7.5 m (25 ft.)											7633	7633
											(16,037)	(16,037)
6.0 m (20 ft.)									9950	9950	8901	8901
									(21,588)	(21,588)	(18,979)	(18,979)
4.5 m (15 ft.)							13 443	13 443			10 429	9496
							(29,087)	(29,087)	(25,768)	(25,768)	(22,249)	(20,365)
3.0 m (10 ft.)			27 858	27 858	19 701	19 701	15 613	15 613	13 211	11 922	11 668	9138
			(59,723)	(59,723)	(42,441)	(42,441)	(33,756)	(33,756)	(28,648)	(25,636)	(25,370)	(19,608)
1.5 m (5 ft.)			17 982	17 982	22 902	21 457	17 611	15 185	14 493	11 368	12 479	8786
			(42,685)	(42,685)	(49,431)	(46,208)	(38,090)	(32,691)	(31,408)	(24,446)	(27,092)	(18,859)
Ground Line			16 168	16 168	25 049	20 401	19 134	14 486	15 522	10 905	12 398	8485
			(37,320)	(37,320)	(54,167)	(43,894)	(41,411)	(31,172)	(33,628)	(23,447)	(26,642)	(18,217)
-1.5 m (-5 ft.)	10 052	10 052	18 748	18 748	26 037	19 791	20 004	14 018	15 526	10 574	12 169	8269
	(22,701)	(22,701)	(42,960)	(42,960)	(56,367)	(42,552)	(43,307)	(30,154)	(33,379)	(22,735)	(26,160)	(17,762)
-3.0 m (-10 ft.)	14 711	14 711	23 606	23 606	25 938	19 532	20 117	13 777	15 333	10 396	12 064	8170
	(33,198)	(33,198)	(53,968)	(53,968)	(56,149)	(41,985)	(43,523)	(29,635)	(32,975)	(22,359)	(25,958)	(17,572)
-4.5 m (-15 ft.)	20 335	20 335	30 826	30 826	24 730	19 554	19 330	13 751	15 326	10 389		
	(46,013)	(46,013)	(70,608)	(68,371)	(53,432)	(42,044)	(41,701)	(29,595)	(32,988)	(22,372)		
-6.0 m (-20 ft.)	27 672	27 672	29 088	29 088	22 149	19 843	17 275	13 957	13 248	10 618		
	(62,903)	(62,903)	(62,555)	(62,555)	(47,558)	(42,706)	(36,921)	(30,084)	(27,798)	(22,951)		
-7.5 m (-25 ft.)			22 773	22 773	17 355	17 355						
			(48,117)	(48,117)	(36,413)	(36,413)						
With 3.5-m ³ (4.6 cu. yd.) bucket, 2.9-m (9 ft. 6 in.) BE arm, 6.8-m (22 ft. 4 in.) BE boom, and 900-mm (36 in.) double-bar grouser shoes												
7.5 m (25 ft.)							14 395	14 395				
							(31,612)	(31,612)				
6.0 m (20 ft.)					17 527	17 527	15 276	15 276				
					(37,885)	(37,885)	(33,224)	(33,224)				
4.5 m (15 ft.)					20 472	20 472	16 699	15 334	14 652	10 986		
					(44,111)	(44,111)	(36,197)	(32,957)	(31,942)	(23,474)		
3.0 m (10 ft.)					23 433	21 147	18 261	14 660	15 368	10 693		
					(50,516)	(45,523)	(39,522)	(31,520)	(33,393)	(22,931)		
1.5 m (5 ft.)					25 431	20 214	19 475	14 101	15 377	10 394		
					(54,940)	(43,472)	(42,140)	(30,312)	(33,018)	(22,308)		
Ground Line					26 021	19 726	19 945	13 750	15 190	10 220		
					(56,317)	(42,385)	(43,144)	(29,551)	(32,649)	(21,965)		
-1.5 m (-5 ft.)			33 521	32 367	25 148	19 608	19 302	13 648				
			(72,778)	(69,314)	(54,427)	(42,117)	(41,640)	(29,342)				
-3.0 m (-10 ft.)	34 294	34 294	29 559	29 559	22 510	19 819	16 667	13 874				
	(77,983)	(77,983)	(63,977)	(63,977)	(48,496)	(42,597)	(35,284)	(29,914)				
-4.5 m (-15 ft.)			22 634	22 634	16 493	16 493						
			(48,277)	(48,277)	(34,298)	(34,298)						

Buckets

ZX670LC-5

A full line of buckets is offered to meet a wide variety of applications. Digging forces are with power boost. Buckets are equipped with ESCO teeth standard. Replaceable cutting edges and a variety of teeth are available through Hitachi parts. Optional side cutters add 150 mm (6 in.) to bucket widths. Capacities are SAE heaped ratings.

Type Bucket	Bucket Width		Bucket Capacity		Bucket Weight		Bucket Dig Force		Arm Dig Force 3.6 m (11 ft. 10 in.)		Arm Dig Force 4.2 m (13 ft. 9 in.)		Arm Dig Force 5.3 m (17 ft. 5 in.)		ME Arm Dig Force 2.9 m (9 ft. 6 in.)		Bucket Tip Radius		Number of Teeth
	mm	in.	m ³	cu. yd.	kg	lb.	kN	lb.	kN	lb.	kN	lb.	kN	lb.	kN	lb.	mm	in.	
Extreme-Duty Plate Lip	1219	48	2.65	3.5	3396	7,487	275	61,851	242	54,423	220	49,448	189	42,497	290	65,260	2281	89.79	3
	1372	54	3.06	4	3546	7,817	275	61,851	242	54,423	220	49,448	189	42,497	290	65,260	2281	89.79	3
	1524	60	3.53	4.6	3795	8,368	275	61,851	242	54,423	220	49,448	189	42,497	290	65,260	2281	89.79	3
Heavy-Duty High Capacity	914	36	1.80	2.4	2664	5,873	275	61,851	242	54,423	220	49,448	189	42,497	290	65,260	2281	89.79	3
	1067	42	2.22	2.9	2867	6,320	275	61,851	242	54,423	220	49,448	189	42,497	290	65,260	2281	89.79	3
	1219	48	2.06	2.7	2966	6,540	275	61,851	242	54,423	220	49,448	189	42,497	290	65,260	2281	89.79	4
	1372	54	3.09	4	3129	6,898	275	61,851	242	54,423	220	49,448	189	42,497	290	65,260	2281	89.79	5
	1524	60	3.54	4.6	3302	7,280	275	61,851	242	54,423	220	49,448	189	42,497	290	65,260	2281	89.79	5
Heavy Capacity Dirt	1829	72	4.44	5.8	3593	7,921	275	61,851	242	54,423	220	49,448	189	42,497	290	65,260	2281	89.79	6
	2032	80	5.05	6.6	3916	8,634	275	61,851	242	54,423	220	49,448	189	42,497	290	65,260	2281	89.79	6
	2184	86	4.59	6	3941	8,688	287	64,421	246	55,278	223	50,152	58	13,013	295	66,427	2190	86.23	6
Heavy-Duty	914	36	1.30	1.7	2252	4,964	326	73,327	258	57,940	233	52,331	198	44,597	312	70,090	1924	75.75	3
	1067	42	1.58	2.1	2594	5,719	326	73,327	258	57,940	233	52,331	198	44,597	312	70,090	1924	75.75	4
	1219	48	1.90	2.5	2722	6,000	326	73,327	258	57,940	233	52,331	198	44,597	312	70,090	1924	75.75	4
	1372	54	2.19	2.9	2858	6,302	326	73,327	258	57,940	233	52,331	198	44,597	312	70,090	1924	75.75	5
	1524	60	2.52	3.3	3062	6,750	326	73,327	258	57,940	233	52,331	198	44,597	312	70,090	1924	75.75	5
Truck Loading	1930	76	3.75	4.9	3043	6,709	287	64,421	246	55,278	223	50,152	58	13,013	295	66,427	2189	86.20	6
	2083	82	4.05	5.3	3292	7,257	287	64,421	246	55,278	223	50,152	58	13,013	295	66,427	2189	86.20	7

Bucket Selection Guide*

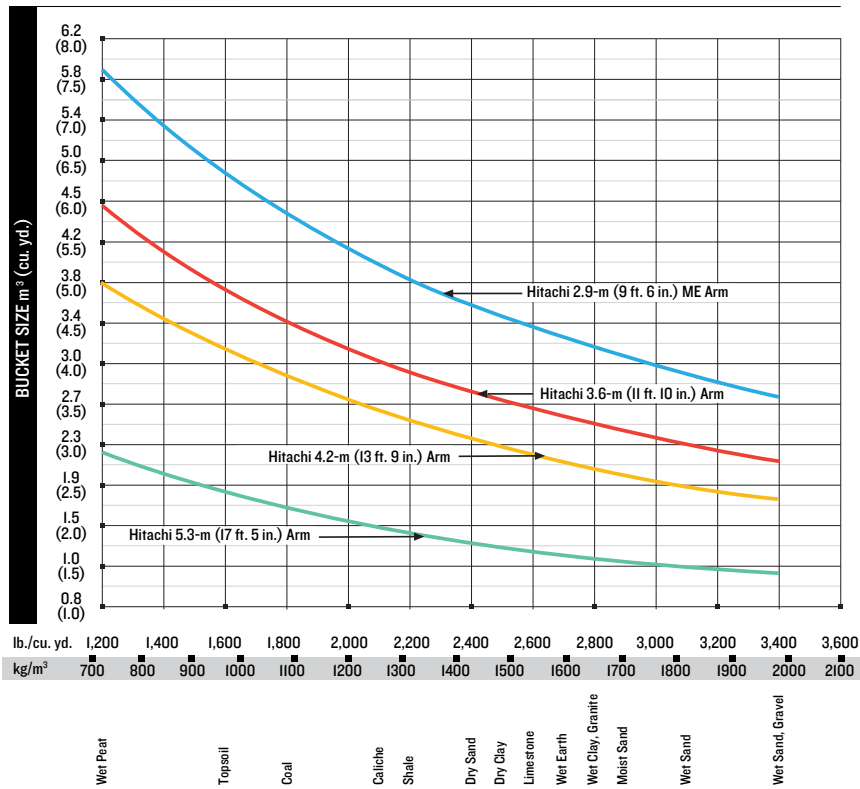

* Contact your Hitachi dealer for optimum bucket and attachment selections. These recommendations are for general conditions and average use. Does not include optional equipment such as thumbs or couplers. Larger buckets may be possible when using light materials, for flat and level operations, less compacted materials, and volume loading applications such as mass-excavation applications in ideal conditions. Smaller buckets are recommended for adverse conditions such as off-level applications, rocks, and uneven surfaces. Bucket capacity indicated is SAE heaped.

DASH-5

ADDITIONAL EQUIPMENT

Key: ● Standard ▲ Optional or special kit

670 Engine

- Auto-idle system
- Batteries (2 – 12 volt)
- Coolant recovery tank
- Dual-element dry-type air filter
- Electronic engine control
- Enclosed fan guard (conforms to SAE J1308)
- Engine coolant to –37 deg. C (–34 deg. F)
- Automatic belt-tension device
- Fuel filter with water separator
- Full-flow oil filter
- Turbocharger with charge air cooler
- Cool-on-demand hydraulic-driven fan
- Glow-plug start aid
- 500-hour engine-oil-change interval
- 70% (35 deg.) off-level capability
- Hydraulic fan reverser

Hydraulic System

- Reduced-drift valve for boom down, arm in
- Auxiliary hydraulic valve section
- Spring-applied, hydraulically released automatic swing brake
- Auxiliary hydraulic-flow adjustments through monitor
- Auto power lift
- 4,000-hour hydraulic-oil-change interval
- ▲ Auxiliary pilot and electric controls
- ▲ Hydraulic filter restriction indicator kit
- ▲ Load-lowering control / Anti-drift device
- ▲ Single-pedal propel control
- ▲ Control pattern change valve

Undercarriage

- Planetary drive with axial-piston motors
- Propel motor shields
- Spring-applied, hydraulically released automatic propel brake
- Track guides, front idler and center
- 2-speed propel with automatic shift
- Upper carrier rollers (3)
- Sealed and lubricated track chain
- ▲ Double-bar grouser shoes, 600 mm (24 in.)
- ▲ Double-bar grouser shoes, 750 mm (30 in.)
- ▲ Double-bar grouser shoes, 900 mm (36 in.)

670 Upperstructure

- Right-hand, left-hand, and counterweight mirrors
- Vandal locks with ignition key: Cab door / Fuel cap / Service doors / Toolbox
- Debris screen in side panel
- Remote-mounted engine oil and fuel filters
- Service platform, left side
- ▲ Counterweight-removal system

Front Attachments

- Centralized lubrication system
- Dirt seals on all bucket pins
- Less-boom-arm option
- ▲ Boom, 7.8 m (25 ft. 7 in.)
- ▲ Boom, mass excavating, 6.8 m (22 ft. 4 in.)
- ▲ Arm, mass excavating, 2.9 m (9 ft. 6 in.)
- ▲ Arm, 3.6 m (11 ft. 10 in.)
- ▲ Arm, 4.2 m (13 ft. 9 in.)
- ▲ Arm, 5.3 m (17 ft. 5 in.)
- ▲ Boom cylinder with plumbing to mainframe for less-boom-arm option
- ▲ Buckets: Heavy duty / Heavy-duty high capacity / Side cutters and teeth

Operator's Station

- Adjustable independent-control positions (levers-to-seat, seat-to-pedals)
- AM/FM radio
- Auto climate control/air conditioner/heater/pressurizer, 5.9 kW (20,000 Btu/hr.)
- Built-in Operator's Manual storage compartment and manual
- Cell-phone power outlet, 12 volt, 60 watt, 5 amp
- Coat hook
- Deluxe suspension cloth seat with 100-mm (4 in.) adjustable armrests
- Floor mat
- Front windshield wiper with intermittent speeds
- Gauges (illuminated): Engine coolant / Fuel
- Horn, electric
- Hour meter, electric
- Hydraulic shutoff lever, all controls
- Hydraulic warm-up control
- Interior light
- Large cup holder

670 Operator's Station (continued)

- Machine Information Center (MIC)
 - Mode selectors (illuminated): Power modes (3) / Travel modes (2 with automatic shift) / Work mode (1)
 - Multifunction, color LCD monitor with: Diagnostic capability / Multiple-language capabilities / Maintenance tracking / Clock / System monitoring with alarm features: Auto-idle indicator, engine air cleaner restriction indicator light, engine check, engine coolant temperature indicator light with audible alarm, engine oil pressure indicator light with audible alarm, low-alternator-charge indicator light, low-fuel indicator light, fault code alert indicator, fuel-rate display, wiper-mode indicator, work-lights-on indicator, and work-mode indicator
 - Fluid-level switch and indicator light for engine coolant and engine oil
 - Motion alarm with cancel switch (conforms to SAE J994)
 - Propel pedals and levers
 - SAE 2-lever control pattern
 - Seat belt, 51 mm (2 in.), retractable
 - Tinted glass
 - Transparent tinted overhead hatch
 - Hot/cold beverage compartment
 - ▲ Monitor system with alarm features: Hydraulic oil filter restriction indicator light
 - ▲ Protection screens for cab front, rear, and side
 - ▲ Seat belt, 76 mm (3 in.), non-retractable
 - ▲ Window vandal-protection covers
- ### Electrical
- 50-amp alternator
 - Blade-type multi-fused circuits
 - Positive-terminal battery covers
 - ZXLink™ wireless communication system (available in specific countries; see your dealer for details)
 - ▲ Cab extension wiring harness
- ### Lights
- Work lights: Halogen / 2 mounted on boom / 1 mounted on frame / 2 mounted on top of cab

See your Hitachi dealer for further information.

Net engine power is with standard equipment including air cleaner, exhaust system, alternator, and cooling fan, at test conditions specified per ISO 9249. No derating is required up to 2000-m (6,560 ft.) altitude. Specifications and design subject to change without notice. Wherever applicable, specifications are in accordance with SAE standards. Except where otherwise noted, these specifications are based on a unit with 1370-mm (54 in.) bucket, 900-mm (36 in.) double-bar grouser shoes, 10 400-kg (22,928 lb.) counterweight, full fuel tank, and 79-kg (175 lb.) operator.

HITACHI

hitachiconstruction.com