

HITACHI

DASH 3



ZAXIS 60USB-3

- Engine Rated Power: 54 hp (40.5 kW) @ 2,000 rpm
- Operating Weight: 13,653 lb. (6193 kg)
- Backhoe Bucket: 6.8 cu. ft. (0.19 m³)

ZAXIS 60USB-3 SPECIFICATIONS

Engine

Manufacturer and Model	Yanmar 4TNV98
Non-Road Emission Standards	certified to EPA interim Tier-4 emissions
Displacement	194 cu. in. (3.2 L)
Net Power (ISO9249)	54 hp (40.5 kW) @ 2,000 rpm

Powertrain

Each track independently driven by hydrostatic axial-piston motor connected to 2-stage planetary gear-reduction box

Maximum Travel Speed

Low	1.6 mph (2.5 km/h)
High	2.8 mph (4.5 km/h)

Hydraulics

Closed center, load sensing

Main Pumps one variable-displacement pump

Maximum Rated Flow 38 gpm (144 L/m)

Pilot Pump one gear

Maximum Rated Flow 2.7 gpm (10 L/m)

Auxiliary Flow 22.5 gpm (85 L/m)

Controls hydraulic pilot-operated for boom, arm, bucket, swing, boom swing, blade, travel, and auxiliary functions

Upperstructure

Counterweight

Standard 1,676 lb. (760 kg)

Additional 573 lb. (260 kg)

Independent Swing Boom

Left 80 deg.

Right 60 deg.

Tail Swing short

Swing Mechanism

Swing Brake spring applied, hydraulically released, automatic

Swing Speed 9.5 rpm

Ground Pressure

Standard Arm/Standard Counterweight 4.93 psi (34 kPa)

Long Arm/Additional Counterweight 5.16 psi (36 kPa)

Serviceability

Refill Capacities

Fuel Tank 32 gal. (120 L)

Engine Oil with Filter 3 gal. (11.2 L)

Hydraulic System 11 gal. (41 L)

Operating Weights

With Full Fuel Tank, 175-lb. (79 kg) Operator, and 6.8-cu.-ft. (0.19 m ³) Bucket 4-ft. 11-in. (1.5 m) Standard Arm, 1,676-lb. (760 kg) Standard Counterweight, and Rubber Tracks	13,653 lb. (6193 kg)
4-ft. 11-in. (1.5 m) Standard Arm, Standard Counterweight, and Steel Tracks	13,774 lb. (6248 kg)
6-ft. 1-in. (1.85 m) Long Arm, 573-lb. (260 kg) Additional Counterweight, and Rubber Tracks	14,299 lb. (6486 kg)
6-ft. 1-in. (1.85 m) Long Arm, 573-lb. (260 kg) Additional Counterweight, and Steel Tracks	14,420 lb. (6541 kg)

Operating Dimensions

	Arm Length 4 ft. 11 in. (1.5 m)	Arm Length 6 ft. 1 in. (1.85 m)
Arm Breakout Force	6,969 lb. (31 kN)	6,070 lb. (27 kN)
Bucket Breakout Force	9,217 lb. (41 kN)	9,217 lb. (41 kN)
A Maximum Digging Reach	20 ft. 5 in. (6.23 m)	21 ft. 6 in. (6.56 m)
B Maximum Digging Depth	12 ft. 4 in. (3.77 m)	13 ft. 6 in. (4.12 m)
C Maximum Digging Height	19 ft. 7 in. (5.96 m)	20 ft. 4 in. (6.19 m)
D Maximum Dumping Height	13 ft. 8 in. (4.17 m)	14 ft. 5 in. (4.40 m)
E Minimum Swing Radius	8 ft. 1 in. (2.47 m)	8 ft. 5 in. (2.56 m)
F Transport Length	18 ft. 11 in. (5.76 m)	19 ft. (5.79 m)
G Tail Swing Radius	4 ft. 3 in. (1.30 m)	4 ft. 8 in. (1.42 m)

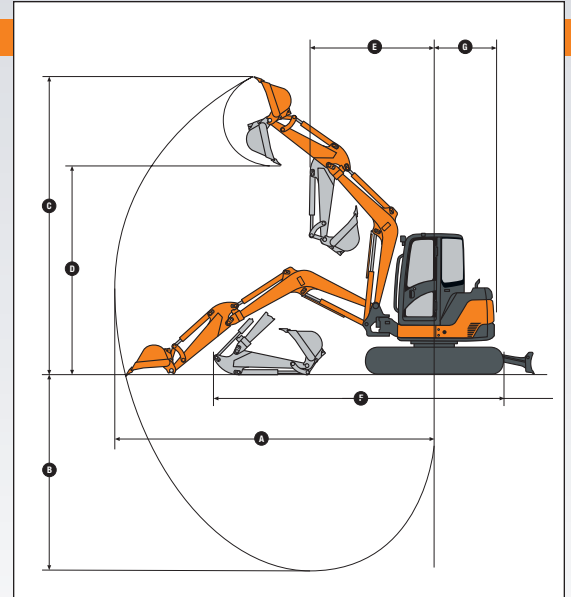

Machine Dimensions

Blade Width	6 ft. 7 in. (2.00 m)
Blade Height	1 ft. 4 in. (0.42 m)
H Overall Height	8 ft. 5 in. (2.56 m)
I Track Width	1 ft. 4 in. (0.40 m)
J Undercarriage Width	6 ft. 7 in. (2.00 m)
K Ground Clearance	1 ft. 1 in. (0.34 m)
L Engine Cover Height	5 ft. 2 in. (1.57 m)
M Maximum Blade Lift Above Ground	1 ft. 6 in. (0.45 m)
N Maximum Blade Drop Below Ground	1 ft. 3 in. (0.39 m)
O Sprocket Center To Idler Center	6 ft. 6 in. (1.99 m)
P Track Length	8 ft. 2 in. (2.50 m)
Q Counterweight Clearance	2 ft. (0.62 m)
R Overall Width	6 ft. 7 in. (2.00 m)

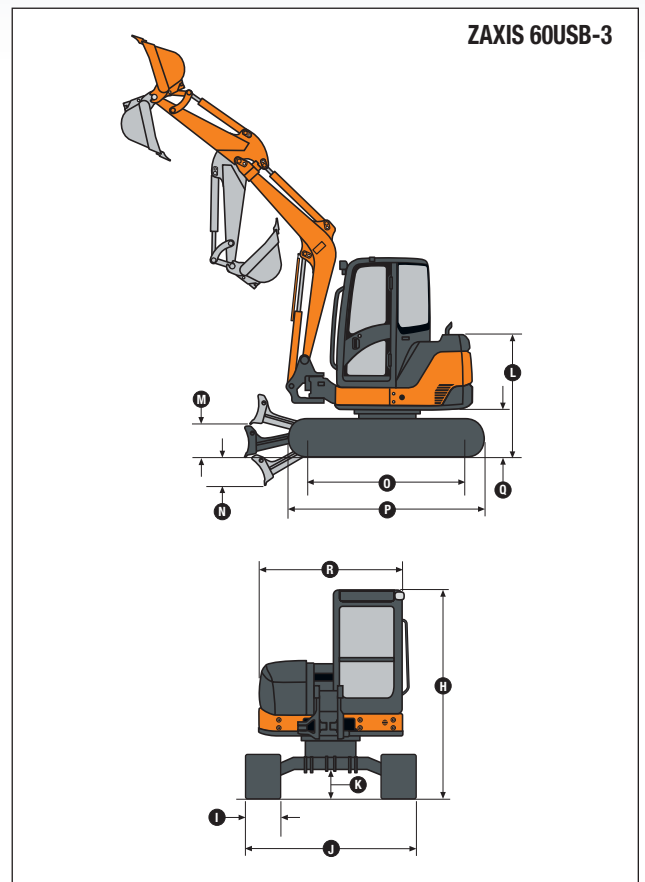

Lift Capacities

	4-ft. 11-in. (1.5 m) standard arm, 1,676-lb. (760 kg) standard counterweight, and rubber tracks	4-ft. 11-in. (1.5 m) standard arm, 1,676-lb. (760 kg) standard counterweight, and steel tracks	6-ft. 1-in. (1.85 m) long arm, 573-lb. (260 kg) additional counterweight, and rubber tracks	6-ft. 1-in. (1.85 m) long arm, 573-lb. (260 kg) additional counterweight, and steel tracks
Ground Level at 10-ft. (3.05 m) Radius				
Lifting Over Front	5,954 lb. (2701 kg)	5,954 lb. (2701 kg)	7,802 lb. (3539 kg)	7,802 lb. (3539 kg)
Lifting Over Side	2,990 lb. (1356 kg)	3,050 lb. (1383 kg)	3,372 lb. (1530 kg)	3,432 lb. (1557 kg)

Equipment

Key ● Standard Equipment ▲ Optional or Special Equipment

Engine

- Certified to EPA interim Tier-4 emissions
- Engine coolant to -34 deg. F (-37 deg. C)
- Engine preheater
- Fan guard
- Fuel/water separator
- Full-flow oil filter
- Isolation mounted
- Key start switch with electric fuel shutoff
- Single dry-type air filter
- Under-hood muffler

Hydraulic System

- Auxiliary function foot control
- Auxiliary hydraulic lines with quick-couplers to end of boom
- Auxiliary return-flow selector valve
- Axial-piston swing motor
- Boom-swing foot control
- Excavator-to-backhoe control pattern change valve
- Closed-center load sensing with one variable-displacement pump and one fixed-gear pump
- Hydraulic pilot-operated controls for boom, arm, bucket, swing, boom swing, blade, travel, and auxiliary functions
- Wet-disc swing brake

Undercarriage

- Planetary final drive
- Propel motor shield
- Rubber track, 16 in. (400 mm)
- Two-speed axial-piston propel motors
- ▲ Steel track, 16 in. (400 mm) with triple semi-grousers
- ▲ Rubber crawler pad, 16 in. (400 mm)

Upperstructure

- 360-deg. rotation
- Counterweight, 1,676 lb. (760 kg)
- Hinged service-access doors

Upperstructure (continued)

- One-piece airtight floor
- Independent-swing boom (80-deg. left, 60-deg. right)
- Toolbox
- ROPS/TOPS/FOPS (cab) with air conditioning and heater
- Vandal protection for service doors, fuel cap, and toolbox
- Reduced-tail-swing configuration

Front Attachments

- Arm, 4 ft. 11 in. (1.50 m)
- ▲ Long arm, 6 ft. 1 in. (1.85 m), includes additional 573-lb. (260 kg) counterweight
- Articulation hose shield
- Backfill blade, 6 ft. 7 in. (2.00 m)
- Boom, 9 ft. 9 in. (2.965 m)
- Mechanical quick-coupler
- ▲ Augers: Planetary / Chain drive / Bits / Bit adapters
- ▲ Clamp
- ▲ Hammers: Points / Tools
- ▲ Quick-coupler buckets: Bucket teeth / Ditching / Heavy-duty

Operator's Station

- Horn
- Hour meter
- Instrumentation lights
- Monitor system: Preheat indicator / Engine oil pressure indicator / Alternator voltage indicator / Fuel gauge and fuel level indicator / Engine coolant temperature gauge and engine coolant temperature indicator / Hour meter / Work lights indicator
- Motion alarm with cancel switch
- Propel levers and foldable pedals
- Two travel speeds with automatic shifting
- Seat belt, 2 in. (51 mm), retractable
- Suspension seat (cloth)
- ▲ Front screen
- ▲ Rear secondary exit kit

Electrical

- 12-volt accessory outlet
- 50-amp alternator
- Low-maintenance battery
- Blade-type multi-fused circuits
- Positive terminal battery covers
- ▲ ZXLink™ wireless communication system

Lights

- Work lights: Halogen / One mounted on operator's station / One mounted on boom
- Work lights switch

Control Owning and Operating Costs

Customer Personal Service (CPS) is part of Hitachi's proactive, fix-before-fail strategy on machine maintenance that will help control costs, increase profits, and reduce stress. Included in this comprehensive lineup of ongoing programs and services are:

Fluid analysis program – tells you what's going on inside all of your machine's major components so you'll know if there's a problem before you see a decline in performance. Fluid analysis is included in most extended coverage and preventive-maintenance agreements.

Preventive Maintenance (PM) agreements – give you a fixed cost for maintaining a machine for a given period of time. They also help you

avoid downtime by ensuring that critical maintenance work gets done right and on schedule. On-site preventive maintenance service performed where and when you need it helps protect you from the expense of catastrophic failures and lets you avoid waste-disposal hassles.

Extended warranty coverage – gives you a fixed cost for machine repairs for a given period of time so you can effectively manage expenses. Whether you work in a severe-service setting, or you just want to spread the risk of doing business, this is a great way to custom-fit coverage to your operation. Choose from engine, powertrain, powertrain with hydraulics, or full-machine two-year/2,000-hour or three-year/3,000-hour coverage. An extended coverage contract travels well because it's backed by Hitachi and is honored by all Hitachi construction dealers.

What's more, extended coverage is fully transferable at no extra charge, so it adds value at trade-in.

Customer Support Advisors (CSAs) – Hitachi believes the CSA program lends a personal quality to Customer Personal Service (CPS). Certified CSAs have the knowledge and skills for helping make important decisions on machine maintenance and repair. Their mission is to help you implement a plan that's right for your business and take the burden of machine maintenance off your shoulders.

Net engine power is with standard equipment including air cleaner, exhaust system, alternator, and cooling fan at test conditions specified per ISO9249. No derating is required up to 10,000-ft. (3050 m) altitude. Specifications and design subject to change without notice. Wherever applicable, specifications are in accordance with SAE standards. Except where otherwise noted, these specifications are based on a unit with standard equipment, 6.8-cu.-ft. (0.19 m³) bucket, 16-in. (400 mm) rubber tracks, 1,676-lb. (760 kg) counterweight, 4-ft. 11-in. (1.50 m) arm, full fuel tank, and 175-lb. (79 kg) operator.

HITACHI